

# HLA data entry manual

**Guide for entering HLA typing data into the EBMT Registry**

April 2025

---

**EBMT Registry**

EBMT Clinical Research & Registry Department

## Revision history

Date	Version	Description
September 10, 2024	v1.0	First version release
October 24, 2024	v2.0	Update to specify definition of full match
December 6, 2024	v3.0	Updated information on P groups
April 16, 2025	v4.0	Updated links to external websites

## Author list

Prof. Dr. Katharina Fleishhauer (German Cancer Consortium (DKTK), partner site Essen/Düsseldorf, Germany)

Dr. Esteban Arrieta-Bolanos (German Cancer Consortium (DKTK), partner site Essen/Düsseldorf, Germany)

Marie Wilson (BSBMTCT, United Kingdom)

Jorinde Hoogenboom (EBMT, The Netherlands)

Juana Schwartz-Mota (EBMT, The Netherlands)

Annelot van Amerongen (EBMT, The Netherlands)

*For questions or comments, reach out to [registryhelpdesk@ebmt.org](mailto:registryhelpdesk@ebmt.org)*

## Table of contents

<b>Revision history</b>	<b>2</b>
<b>Author list</b>	<b>2</b>
<b>Table of contents</b>	<b>3</b>
Introduction	4
<b>Data entry</b>	<b>6</b>
Patient HLA	6
Molecular HLA results	10
Serological HLA results	18
Donor HLA	23
Number of HLA mismatches	23
Molecular HLA: number of allelic mismatches	24
Serological HLA: number of antigen mismatches	28
Important considerations	32
<b>Useful links</b>	<b>33</b>
<b>References</b>	<b>33</b>
<b>Appendix A - Inheritance genetics schema</b>	<b>34</b>
Example 1	34
Example 2	34
Example 3	35
Example 4	37
Example 5	37
Example 6	38
Example 7	39
<b>Glossary of HLA-related terms</b>	<b>40</b>

## Introduction

HLA data must be entered for allogeneic hematopoietic cell transplants (HCT) reported to the EBMT Registry. It must be reported for every patient (recipient) and every donor. Instructions on how to perform data entry for allogeneic HCT in general can be found in the completion guidelines on the [EBMT Data Collection webpage](#). This document will only focus on the entry of HLA data into the EBMT Registry.

The goal of this document is to support the data entry work for HLA, but also to give some background information about what HLA is and why it should be reported. At the end of the document, a glossary with HLA-related terminology can be found.

HLA, short for human leukocyte antigens, are genes encoding proteins that help the immune system differentiate between self and non-self. There are over 40,000 different variants, the so-called HLA types ([HLA Nomenclature @ hla.alleles.org](#)). HLA is inherited from your biological mother and father (split 50/50) and as a result HLA and ethnicity are closely intertwined, with some HLA markers found more often in certain racial and ethnic groups. This means that if a patient needs an unrelated donor, they are more likely to find a match with an unrelated donor from the same ethnic group than from a different ethnic group.

The following will have all played some role in shaping HLA variations across continents: geographical climates and boundaries, migration, disease localisation, mate selection, fitness to reproduce, to name a few. As the number of individuals with mixed ancestry grows worldwide, this brings bigger challenges for HLA matching. Inherited HLAs in mixed ancestry form even rarer HLA combinations. In addition, because some HLA types on their own are more rare than others, some patients may face a greater challenge in finding a matching donor even though there are over 42 million volunteer donors worldwide. To learn more about donors, consult the website of the World Marrow Donor Association ([World Marrow Donor Association](#)).

A set of HLA genes located on chromosome 6 (6p21.3) are inherited together, one from each biological parent. This set of genes is known as a haplotype. Each individual will therefore have two HLA haplotypes: one from their mother and one from their father. Theoretically the probability of a patient inheriting the same two haplotypes as their sibling, and therefore fully matching with them on the 6 important HLA loci, is 25%. They also have a 25% chance of not inheriting the two identical haplotypes. There is a 50% probability that a patient and their sibling will match on just one of the two haplotypes. In such cases, patient and sibling are said to be haploidentical, hereafter referred to as haplo donors (consult appendix A for a visual representation). Parents are always haploidentical to their children and vice versa. The larger the biological sibling pool is, the greater the chance of finding a fully matched sibling. Many Western society families are small and because of this finding a fully matched sibling donor becomes challenging. As of August 2024, the number of volunteer donor and cord blood units worldwide is over 42 million from 57 different countries (1).

Genetic identity of haplotypes (also called “genotypic identity”) should be confirmed by family studies. These studies involve typing some or all of the following groups of individuals:

- Parents of the patient;
- Offspring (children) of the patient;
- Siblings of the patient (then segregating the haplotypes);
- Other related relatives (e.g. aunts and uncles or cousins. This is mainly for patients who lack a closer related haploidentical donor. They may be older adults without healthy siblings, parents or children).

The results are usually documented in a single report listing all HLA-typed family members. In the Allo HCT Day 0 DCF, within the Donor & Graft Information section, you will be asked to report whether genotypic identity was confirmed by family studies.

HLA molecules play a significant role in disease and immune defence against pathogens, and are beneficial to the immune system. They can also have harmful effects, in particular in the context of transplantation. The degree of HLA matching between the donor and the patient’s HLA types can have an important impact on transplant outcome. The HLA matching status is relevant for the risk of the most frequent post-transplant complications, i.e. relapse of malignant disease, graft-versus-host disease (GvHD), as well as infection. Moreover, antibodies to mismatched HLA can influence the engraftment and reconstitution of new healthy blood and immune cells (called graft rejection or graft failure).

HLA can be divided into two main classes: class I HLA antigens, encoded by the HLA-A, -B, and -C loci, and class II HLA antigens, encoded by the HLA-DRB1, -DQB1, and -DPB1 loci. For each locus, two alleles are expressed (one inherited from the mother and the other from the father as explained above), resulting in a maximum total of 12 (6x2) molecules encoded by HLA-A, -B, -C, -DRB1, -DQB1, DPB1. When the two alleles expressed by a given HLA locus are different, this locus is called heterozygous; if they are the same, it is called homozygous.

In Europe and for the purposes of EBMT data collection the gold standard for a full match between patient and allogeneic donor is when both alleles at each of the 6 HLA loci (HLA-A, -B, -C, -DRB1, -DQB1, -DPB1) are identical. This is known as a 12/12 match. Outside of Europe other organisations, such as the United States’ National Marrow Donor Program (NMDP), may look for 8/8 compatible donors and focus on HLA-A, -B, -C, and -DRB1.

HLA-DPB1 is now included on many typing reports as studies have shown that it has a significant effect on transplant outcome (2). Research has also uncovered that certain mismatches at specific loci are better tolerated than others and these are known as permissible mismatches. For allogeneic HCT a 10/10 or 12/12 sibling donor is considered the optimal donor. In the Allo HCT Day 0 DCF, within the Donor & Graft Information section, you will be asked to report on the relationship between patient and donor and the level of match achieved.

Due to advancements in prophylaxis strategies for graft versus host disease (GvHD), resulting in better immunosuppression post-transplant, the landscape of unrelated donors used in HCT is changing. There is now

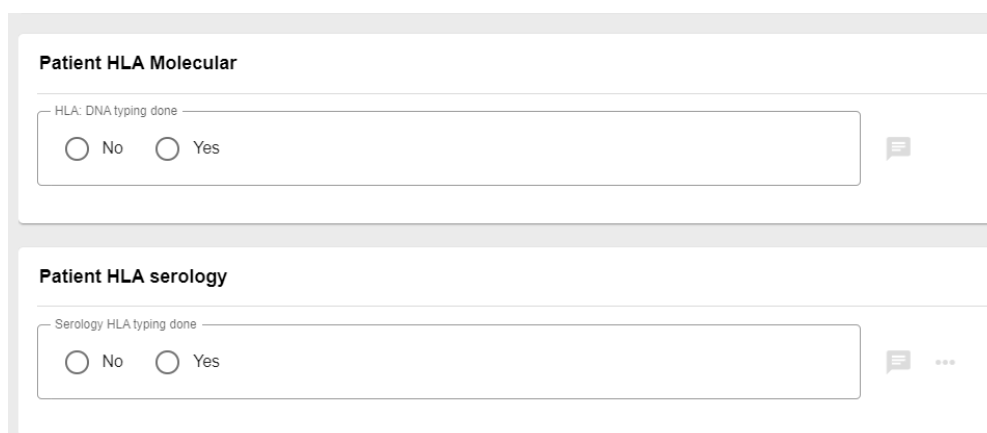
widespread use of haplo donors involving siblings and other biological family members. The use of post-transplant cyclophosphamide (PTCY) and anti-thymocyte globulin (ATG) have been real game changers. As almost everyone has a haplo donor in their family this means life-saving transplants are now available to a wider group of patients. In the Allo HCT Day 0 DCF, within the GvHD Preventative Treatment section, you will be asked to report whether PTCY and/or ATG was given as GvHD preventative treatment.

## Data entry

On the laboratory HLA typing report, identify the donor and the patient and the HLA results required by the EBMT Registry. Currently, only results for HLA-A, -B, -C, -DRB1, -DQB1, and -DPB1 need to be reported if available. Results for additional loci, for instance HLA-DRB3, -DRB4 or -DRB5, do not need to be reported. You may find it helpful to highlight the relevant bits of information to aid with data entry.

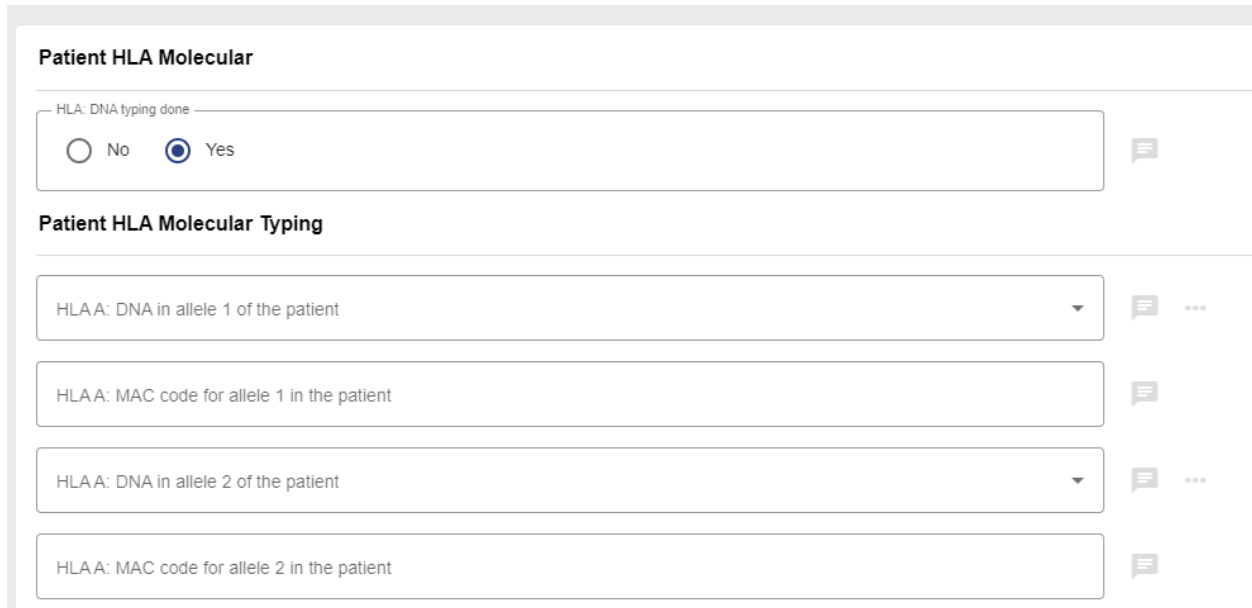
### Patient HLA

The first HLA typing that needs to be entered is that of the patient, you will be advised when to enter this in the Allo HCT Day 0 DCF in the Donor & Graft Information section. The results from the laboratory can be from **molecular typing** or from **serological typing**. Carefully review which results you are entering and where they are to be input. The first question you will be asked is if DNA typing was done by molecular methods (**Figure 1**). When you answer yes to either of the questions in **Figure 1** it will trigger a reveal of hidden fields which allow for full entry of typing results (**Figure 2**).



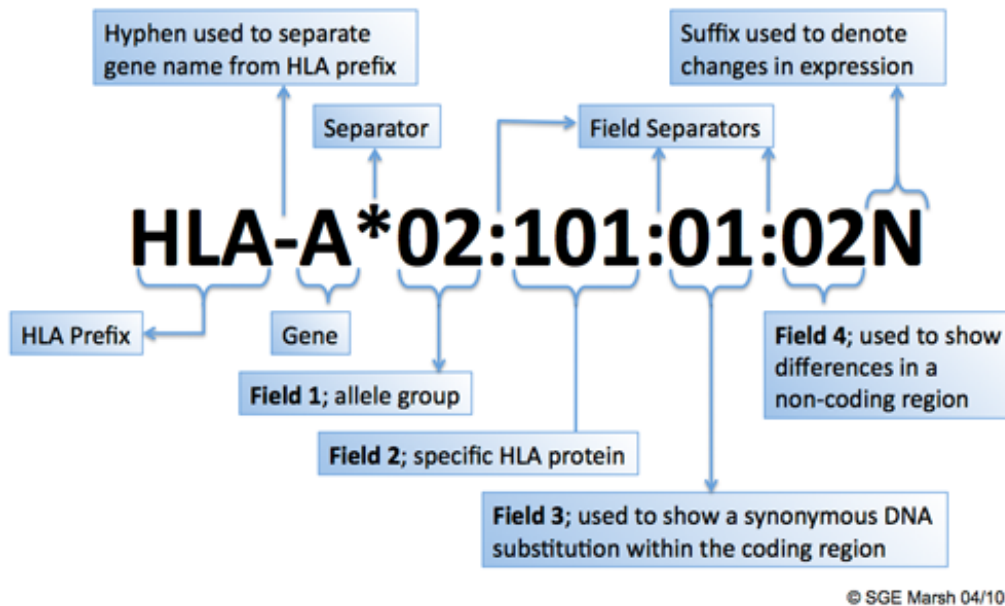
The image shows a screenshot of a web form with two sections. The first section is titled 'Patient HLA Molecular' and contains a question 'HLA: DNA typing done' with two radio button options: 'No' and 'Yes'. To the right of the options is a small speech bubble icon. The second section is titled 'Patient HLA serology' and contains a question 'Serology HLA typing done' with two radio button options: 'No' and 'Yes'. To the right of the options are a speech bubble icon and three dots indicating a menu.

**Figure 1.** Fields in the EBMT Registry capturing molecular and serological HLA typing



**Figure 2. A section of hidden fields in the EBMT Registry when yes is selected for molecular typing**

The molecular typing method is the most common one nowadays. You can identify it because it has an asterisk (\*) between the HLA locus and the HLA allele group given in Field 1 (1<sup>st</sup> set of digits, **Figure 3**), e.g., HLA-A\*02:01 (molecular) corresponds to HLA-A2 (serological). Molecular typing usually provides results at high resolution (at least 2 sets of digits separated by a colon (:)) after the locus designation), examples are A\*02:01, B\*14:02, C\*01:02. The first set of digits are known as field 1. The second set of digits is known as field 2, the third set as field 3 and the fourth and final set as field 4. Each field being separated from the other by a colon for easy identification and reading. Sometimes, you will find a suffix after the last field (field 4). These alleles should be reported completely (all fields plus the suffix). The most important one is the suffix “N” (as in **Figure 3**), because it stands for “Null” and indicates that the allele is not expressed at the cell surface. This of course has potential implications for matching between patient and donor. Other frequent suffixes after the last field are “G” or “P”. They indicate typing ambiguities which regard only certain, less relevant parts of the HLA molecule. There are a few additional suffixes that are less commonly used. For a list of suffixes and their meaning please consult the IMGT website ([G Codes For Reporting of Ambiguous Allele Typings](#), [P Codes For Reporting of Ambiguous Allele Typings](#), [Nomenclature for Factors of the HLA System](#)).



**Figure 3. The structure of the nomenclature for factors of the HLA system.**  
Credit: Anthony Nolan Research Institute.

HLA alleles with suffixes are not to be entered within the HLA MAC (multiple allele codes) fields in the EBMT Registry (further detail on this is given later). These suffixes are different from MAC codes and the allele with suffix can be selected from within the allele drop-down list. Hint: Typing 'N', 'P' or 'G' in a specific HLA DNA field will show all the N, P or G options available to select. This will work for all suffixes (**Figure 4**).

**Patient HLA Molecular Typing**

HLA A: DNA in allele 1 of the patient

p

--

A\*11:03P

A\*11:70P

A\*03:44P

A\*11:02P

**Figure 4. Selecting an allele with a suffix within the DNA allele field**



If you do not have molecular results but only have serological results, you can indicate this in the question ‘Serology HLA typing done’ (**Figure 1**). Serological results look different from molecular results and can be easily identified. The main way to tell if it is serological typing is when there is no asterisk after the HLA gene name. Serological typing does not use MAC codes or suffixes and there will not be any field separators. DRB1\* and DQB1\* will be written as DR and DQ in serological typing results and C\* and DPB1\* show as Cw and DPw. **Figure 5** shows the visual differences between serological and molecular typing on an HLA report. It is also possible that a patient could have a combination of molecular and serological typing.

SEROLOGY		MOLECULAR (low res)		MOLECULAR (high res)	
<u>Patient 1</u>		<u>Patient 1</u>		<u>Patient 1</u>	
A1	A3	A*01	A*03	A*01:AF	A*03:01:01:02N
B12	B8	B*44	B*08	B*44:02:01:11	B*08:01:01
Cw5	Cw7	C*05	C*07	C*05:05:01	C*07:RGFU
DR4	DR12	DRB1*04	DRB1*12	DRB1*04:02:02	DRB1*12:01:01:01
DQ2	DQ2	DQB1*02	DQB1*02	DQB1*02:02:01:02	DQB1*02:10
DPw1	DPw2	DPB1*01	DPB1*02	DPB1*01:01:01:01	DPB1*02:01:02:01
nb B12 can split into B44 or B45					
<u>Patient 2</u>		<u>Patient 2</u>		<u>Patient 2</u>	
A3	A10	A*03	A*25	A*03:01:01:01	A*25:04
B17	B18	B*57	B*18	B*57:01:01:01	B*18:102
Cw5	Cw7	C*05	C*07	C*05:01:01:53Q	C*07:01:01:108
DR2	DR7	DRB1*15	DRB1*07	DRB1*15:03:01:01	DRB1*07:11
DQ1	DQ1	DQB1*06	DQB1*05	DQB1*06:02:01:01	DQB1*05:01:09
DPw3	DPw5	DPB1*03	DPB1*05	DPB1*03:01:18	DPB1*05:01:01:39
nb A10 can split into A25, A26, A34, A66 B17 can split into B57, B58 DR2 can split into DR15, DR16 DQ1 can split into DQ5, DQ6					

**Figure 5. The visual difference between molecular and serological typing on an HLA report**

For more information on the nomenclature of HLA alleles, see [Nomenclature for Factors of the HLA System](#) and **Figure 3**.

**HLA data for patients only needs to be entered once, even if the patient had multiple allogeneic HCTs. If it is reported on the first allogeneic HCT, it does not need to be entered again.**

### Molecular HLA results

Molecular typing refers to HLA types obtained from DNA-based methods. It is the most common typing methodology nowadays. The molecular typing fields in the EBMT Registry look as shown in **Figure 6**. For every locus and allele that has DNA (molecular) results this needs to be entered in the Registry.

**Patient HLA Molecular Typing**

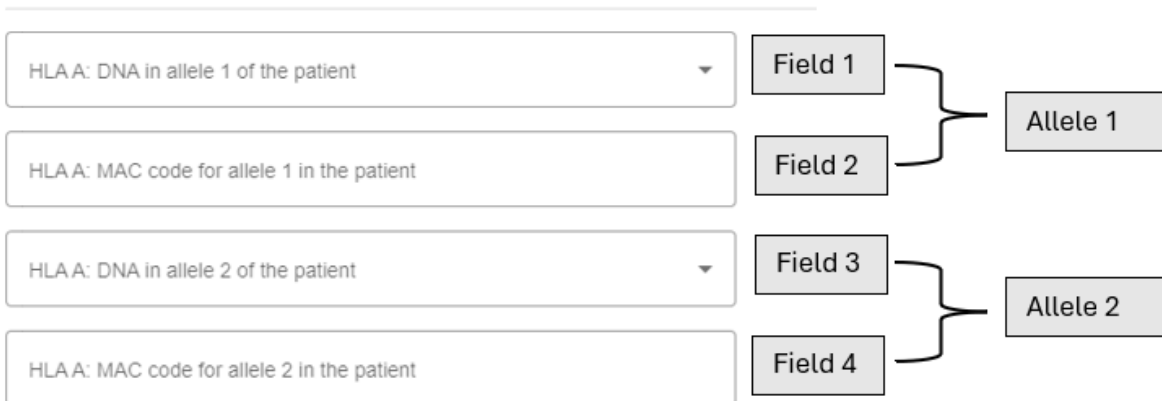
---

HLA A: DNA in allele 1 of the patient	▼	...
HLA A: MAC code for allele 1 in the patient		
HLA A: DNA in allele 2 of the patient	▼	...
HLA A: MAC code for allele 2 in the patient		
HLA B: DNA in allele 1 of the patient	▼	...
HLA B: MAC code for allele 1 in the patient		

**Figure 6. Section of the fields for molecular HLA typing results in the EBMT Registry**

For each HLA locus (A, B, C, DRB1, DQB1, DPB1), there are 4 possible fields where data can be entered (**Figures 7 and 8**)

**Patient HLA Molecular Typing**

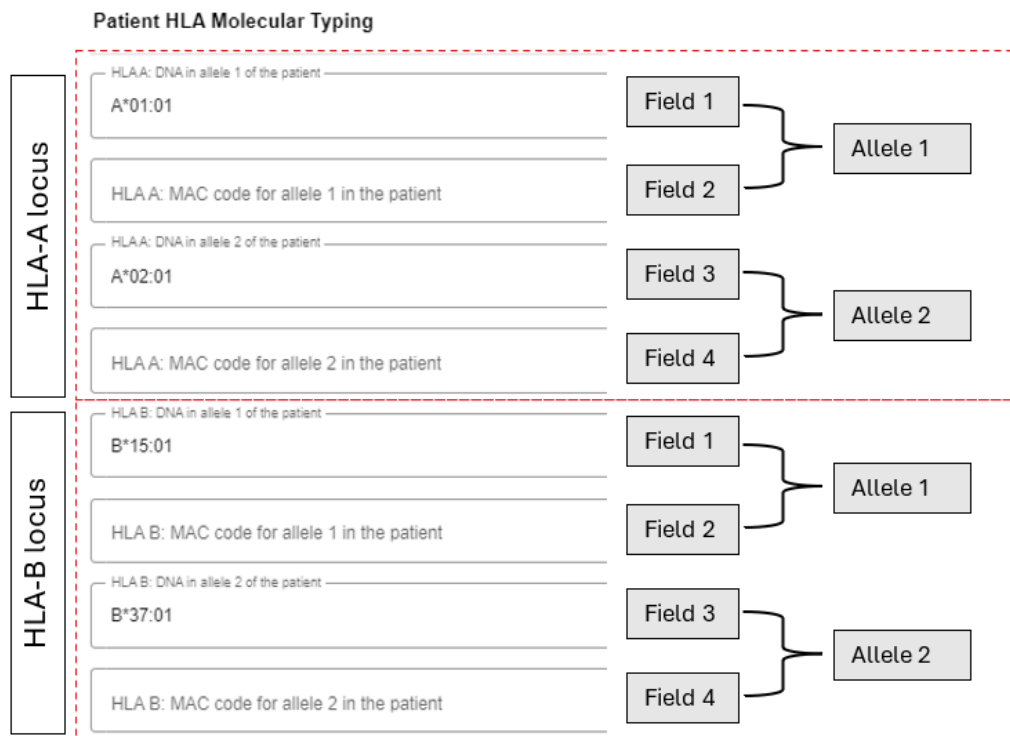


**Figure 7. Four possible data entry fields at each HLA locus for molecular typing**

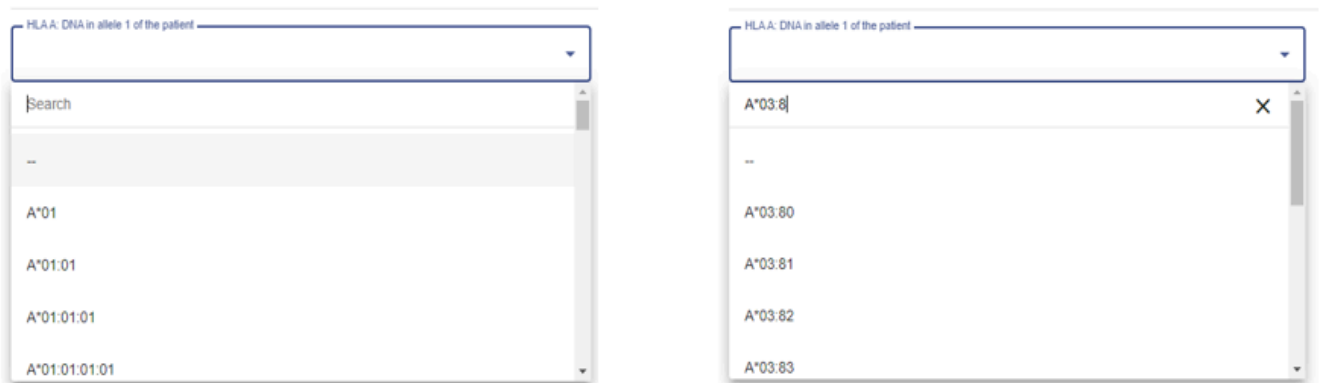
	<b>Data Entry Fields for Each HLA Locus in the EBMT Registry</b>	<b>Type of data Entry Required</b>
Field 1	HLA locus: DNA in allele 1 of the patient	Select-search field & dropdown list
Field 2	HLA locus: MAC code for allele 1 in the patient	Free text
Field 3	HLA locus: DNA in allele 2 of the patient	Select-search field & dropdown list
Field 4	HLA locus: MAC code for allele 2 of the patient	Free text

**Figure 8. DNA Data entry fields for each HLA locus and modes of data entry**

When entering HLA alleles with no ambiguity (i.e. no strings or MAC) at a specific locus they go into fields 1 and 3 (**Figures 7 and 9**). It does not matter if they are entered in the order they are shown on the typing report. These fields are select-search fields, which means there is a dropdown with options to select from, but you can also type the information you are looking for and the relevant option(s) will appear. The dropdowns are very long, so it helps to start typing the HLA information you are looking for (**Figure 10**). You can type the full code you are looking for (e.g. “B\*15:02:08”) or only type a subset and navigate in the dropdown menu from there (e.g. “03:80”). You do not need to type out the name of the HLA locus or the asterisk as the select-search will work when just digits and colons are entered.



**Figure 9. Entry of HLA alleles with no ambiguity**



**Figure 10. Dropdown with options for entering molecular HLA information (left), and dropdown results after typing information (right).**

You only need to enter HLA typing into a MAC field (fields 2 and 4 in **Figures 7 and 9**) when the HLA typing has ambiguity, i.e. MAC has been assigned to an HLA allele or the allele has a string attached to it. If there is no MAC or string given, then you leave fields 2 and 4 empty. MAC are sets of letters that represent groups of HLA alleles (strings) and are used when typing techniques have not been able to resolve allele ambiguity. Although allele strings can be very long, they are still useful as they help to narrow down the alleles that must be considered

when looking for a matched donor. Donors can be eliminated if their alleles at a given locus do not match with any shown in the string at the matching locus of the patient.

MAC are useful for the following reasons:

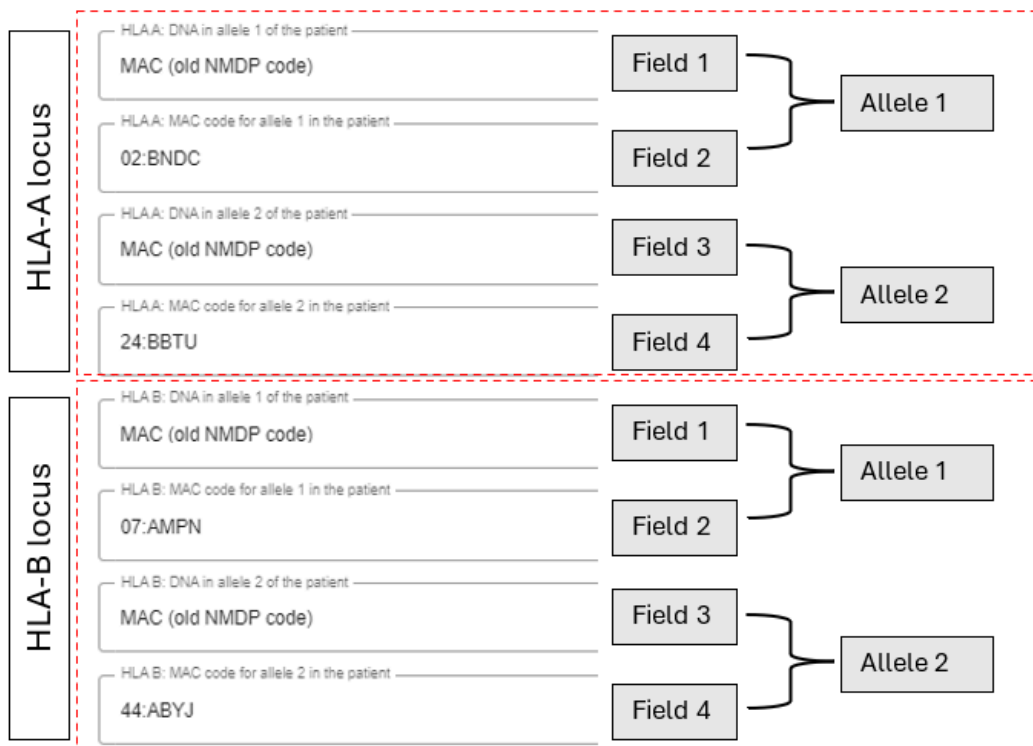
- they reduce the amount of HLA allele information that must be typed out, thus reducing input error;
- they make data entry of HLA quicker;
- they help to keep typing reports succinct.

Examples of how MAC are used in HLA typing to replace allele strings are shown in **Figures 11 and 12**.

Allele String at a Given Locus	MAC Corresponding to the Allele String	Use of MAC with the HLA Allele Group at a Given Locus
A*01:01/02	AB	A*01:AB
DRB1*01:01/04	AD	DRB1*01:AD
DPB1*04:02/105:01	FNVS	DPB1*04:FNVS
B*40:01/40:141/40:151/40:155N/40:179/40:221/40:236/40:238/40:241/40:247/40:249/40:252/40:257/40:262/40:263N/40:264/40:265N/40:272/40:273/40:277/40:278/40:286N	AGSFV	B*40:AGSFV
A*03:01/03:11N/03:17/03:20/03:21N/03:26/03:27/03:37/03:45/03:48/03:49/03:53/03:56/03:58/03:60/03:61/03:62/03:67/03:68N/03:69N	BVTNG	A*03:BVTNG

**Figure 11. Example MAC used for allele strings**

There are MAC which are generic and can be used with any HLA locus (e.g. AB) and MAC that are specific to an HLA locus, i.e. cannot be used with another HLA locus (e.g. BVTNG). MAC gets placed into the second and fourth HLA fields of molecular typing in the EBMT Registry (**Figures 7 and 12**). To enter HLA typing with MAC correctly, you must first select “MAC (old NMDP code)” from the dropdown list in the preceding DNA field. Then in the following MAC field enter the allele group followed by a colon and then the MAC, e.g. 02:BNDC, 24:BBTU (**Figure 12**).



**Figure 12. Entry of alleles with MAC in the EBMT Registry**

Using the MAC Service UI ([MAC UI](#)) you can decode or encode specific MAC. Currently the EBMT Registry MAC fields accept a maximum of 10 characters for HLA A, B and C, and a maximum of 14 characters for DRB1, DQB1 and DPB1. In terms of MAC, the shortest codes are 2 letters long (e.g. AB) and the longest are 5 letters long (e.g. EXJZP). **Figure 13** shows the two different ways that ambiguous molecular typing may be presented on an HLA report. The top picture shows allelic strings at various HLA loci, while the bottom picture shows the strings represented as MAC on the typing report. The correct way to enter this information is shown in **Figure 14**. The different loci have been colour coded to make visual mapping of data easier.

**HLA Typing Results:**

Test Results:		
Locus Name		
HLA A	A*01:01/04N/06/07/09	A*02:01/09/43N/66/75
HLA B	B*08:01/11/15	B*15:01/38/50/60/70/71
HLA C	C*03:02/04/05/06/08/09/10	C*07:01/05/06/14/16
HLA DRB1	DRB1*03:01/11/15/16/18/19/20/22	DRB1*04:01/13/21/33/35/38
HLA DRB4		
HLA DQA1		
HLA DQB1	DQB1*02:01	DQB1*03:01/09/10/13
HLA DPA1		
HLA DPB1	DPB1*01:01	DPB1*04:02

**HLA Typing Results:**

**Test Results:**

Locus Name		
HLA A	A*01:BESH	A*02:BEME
HLA B	B*08:EYC	B*15:BCNT
HLA C	C*03:HBU	C*07:AFZT
HLA DRB1	DRB1*03:VEV	DRB1*04:TSU
HLA DRB4		
HLA DQA1		
HLA DQB1	DQB1*02:01	DQB1*03:VGU
HLA DPA1		
HLA DPB1	DPB1*01:01	DPB1*04:02

**Figure 13. HLA typing with allelic strings (top picture) and with MAC (bottom picture)**  
(image has been colour coded to aid visual mapping to Figure 14)

**Figure 14. Entry of HLA with MAC into the EBMT Registry** (using HLA typing in Figure 13. Image has been colour coded to aid visual mapping)

For heterozygous HLA loci (i.e. the HLA alleles are different at a specific locus), you will see two HLA types in the results, e.g. HLA-A\*01:01, 02:01 and both should be entered into the EBMT Registry (**Figures 15 and 16**). Where only one result is reported for a certain locus (possible homozygous), you should enter the reported result under the 1<sup>st</sup> allele. For the 2<sup>nd</sup> allele, use the code 'only one value reported' (**Figures 15 and 16**). This is important

because if you leave the second HLA type empty, it is not clear if the typing was homozygous or if the insertion of the second allele was forgotten.

**HLA Typing Results:**

**Test Results:**

Locus Name			
HLA A	A*01:01	A*03:01	Heterozygous HLA
HLA B	B*08:01	-	Homozygous HLA
HLA C	C*07:01	-	
HLA DRB1	DRB1*03:01	-	
HLA DRB3	DRB3*01:01	-	
HLA DQA1	DQA1*05:01	-	
HLA DQB1	DQB1*02:01	-	Homozygous HLA
HLA DPA1	DPA1*01:03	DPA1*02:01	
HLA DPB1	DPB1*01:01	DPB1*03:01	Heterozygous HLA

**Figure 15. Examples of homozygous and heterozygous HLA types on a molecular HLA report**

The form displays fields for DNA and MAC codes for HLA A, B, C, DRB1, DRB3, DQA1, DQB1, DPA1, and DPB1. For heterozygous loci (A and DPB1), two DNA and two MAC code fields are present. For homozygous loci (B, C, and DQB1), only one DNA and one MAC code field are present, with the text 'Only one value reported' displayed below the DNA field.

**Figure 16. Entry of heterozygous and homozygous molecular HLA types into the EBMT Registry (using HLA typing in Figure 15. The blue border indicates homozygous HLA and the red border indicates heterozygous HLA)**

If results have not been provided by the laboratory for a certain locus (both alleles), please select 'Not evaluated'. This becomes available to select when you click on the three dots to the right side of the field (**Figure 17**). This is



important because if you leave fields for that locus empty, it is not clear if the typing has not been provided by the laboratory or if the insertion of the typing was forgotten for this locus.

**Patient HLA Molecular**

HLA: DNA typing done

No  Yes

---

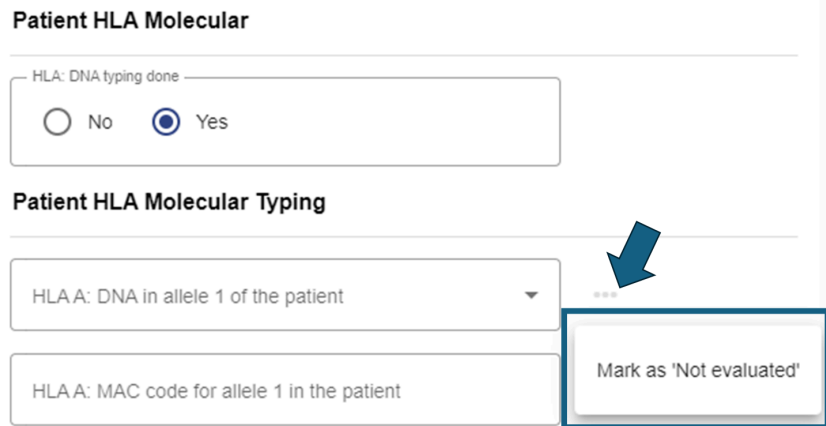
**Patient HLA Molecular Typing**

HLA A: DNA in allele 1 of the patient

HLA A: MAC code for allele 1 in the patient

\*\*\*

Mark as 'Not evaluated'



**Figure 17. Instruction on how to mark a DNA field as not evaluated**

**Figure 18** shows an example of Molecular HLA typing report with heterozygous, homozygous and empty HLA fields. The correct way to enter this information is depicted in **Figure 19**. The different loci have been colour coded to make visual mapping of data easier.

**HLA Typing Results:**

**Test Results:**

Locus Name		
HLA A	A*24	A*33
HLA B	A*40	A*52
HLA C	-	-
HLA DRB1	DRB1*15	-
HLA DRB4	-	-
HLA DQA1	-	-
HLA DQB1	-	-
HLA DPA1	-	-
HLA DPB1	-	-

**Figure 18. An example molecular HLA typing report with heterozygous, homozygous and empty HLA fields**  
(image has been colour coded to aid visual mapping to Figure 19)

<p>Donor HLA molecular - HLA A: DNA in allele 1 of the donor</p> <p>A*24</p> <p>Donor HLA molecular - HLA A: MAC code for allele 1 in the donor</p> <p>Donor HLA molecular - HLA A: DNA in allele 2 of the donor</p> <p>A*33</p> <p>Donor HLA molecular - HLA A: MAC code for allele 2 in the donor</p>	<p>Donor HLA molecular - HLA DRB1: DNA in allele 1 of the donor</p> <p>DRB1*15</p> <p>Donor HLA molecular - HLA DRB1: MAC code for allele 1 in the donor</p> <p>Donor HLA molecular - HLA DRB1: DNA in allele 2 of the donor</p> <p>Only one value reported</p> <p>Donor HLA molecular - HLA DRB1: MAC code for allele 2 in the donor</p>
<p>Donor HLA molecular - HLA B: DNA in allele 1 of the donor</p> <p>B*40</p> <p>Donor HLA molecular - HLA B: MAC code for allele 1 in the donor</p> <p>Donor HLA molecular - HLA B: DNA in allele 2 of the donor</p> <p>B*52</p> <p>Donor HLA molecular - HLA B: MAC code for allele 2 in the donor</p>	<p>Donor HLA molecular - HLA DQB1: DNA in allele 1 of the donor</p> <p>Not evaluated ∅</p> <p>Donor HLA molecular - HLA DQB1: MAC code for allele 1 in the donor</p> <p>Donor HLA molecular - HLA DQB1: DNA in allele 2 of the donor</p> <p>Not evaluated ∅</p> <p>Donor HLA molecular - HLA DQB1: MAC code for allele 2 in the donor</p>
<p>Donor HLA molecular - HLA C: DNA in allele 1 of the donor</p> <p>Not evaluated ∅</p> <p>Donor HLA molecular - HLA C: MAC code for allele 1 in the donor</p> <p>Donor HLA molecular - HLA C: DNA in allele 2 of the donor</p> <p>Not evaluated ∅</p> <p>Donor HLA molecular - HLA C: MAC code for allele 2 in the donor</p>	<p>Donor HLA molecular - HLA DPB1: DNA in allele 1 of the donor</p> <p>Not evaluated ∅</p> <p>Donor HLA molecular - HLA DPB1: MAC code for allele 1 in the donor</p> <p>Donor HLA molecular - HLA DPB1: DNA in allele 2 of the donor</p> <p>Not evaluated ∅</p> <p>Donor HLA molecular - HLA DPB1: MAC code for allele 2 in the donor</p>

**Figure 19. Entry of HLA typing report with heterozygous, homozygous and empty HLA fields in the EBMT Registry (using HLA typing in Figure 18. Image has been colour coded to aid visual mapping)**

### Serological HLA results

Serologic typing refers to HLA types obtained from assays using sera containing antibodies against the HLA proteins. It was used frequently until the mid-1990’s but much less commonly nowadays. Serologic nomenclature, also explained above under “Patient HLA”, is nevertheless still relevant, in particular for indicating the specificity of anti-HLA antibodies. You also see it used with biological sibling donors as high-resolution typing may not be necessary to establish full or haplo matching.

For serological typing, the fields in the EBMT Registry look as shown in **Figure 20**.

**Patient HLA Serology Typing**

---

HLA A: serology in the patient antigen 1
▼
...

HLA A: serology in the patient antigen 2
▼
...

HLA B: serology in the patient antigen 1
▼
...

HLA B: serology in the patient antigen 2
▼
...

HLA C: serology in the patient antigen 1
▼
...

HLA C: serology in the patient antigen 2
▼
...

**Figure 20. Section of the fields for serological HLA typing results**

For each HLA locus (-A,- B, -Cw, -DR, -DQ, -DPw) 2 fields need to be completed (**Figures 21 and 22**). With serological typing you will not use MAC so these fields are not present in this section (refer to **Figures 11 to 14**)



**Figure 21. Two possible data entry fields at each HLA locus for serological typing**

	Data Entry Fields for Each HLA Locus in the Registry	Type of Data Entry Required
Field 1	HLA locus: serology in the patient antigen 1	Select-search field & dropdown list
Field 2	HLA locus: serology in the patient antigen 2	Select-search field & dropdown list

**Figure 22. Serology data entry fields for each HLA locus**

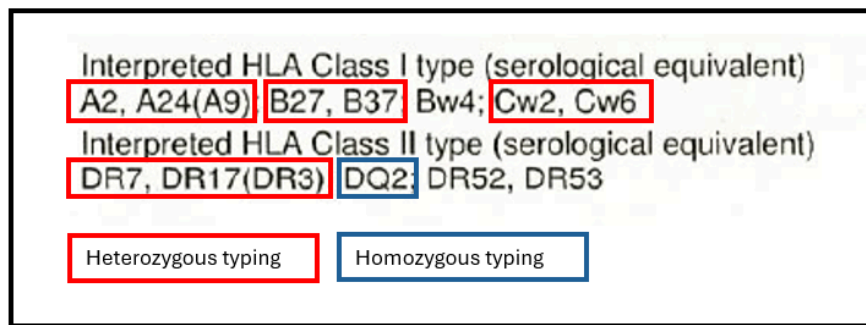
Similar to the molecular data fields, the data entry fields for serology antigen 1 and 2 are select-search fields. This means there is a dropdown with options to select from, but you can also type the information you are looking for and the relevant option(s) will appear. The dropdowns are very long, so it helps to start typing the HLA information you are looking for (**Figure 23**). You can type the full code you are looking for (e.g. “A68(28)”) or only type a subset and navigate in the dropdown menu from there (e.g. “68”). You do not need to type out the name of the HLA locus as the select-search will work when just digits and parentheses (brackets) are entered.

The number in parentheses refers to the relevant broader class of HLA serological antigens. For instance, A68 belongs to the broader class of A28 antigens, therefore it can be indicated as A68(28), or simply as A68. A69 also belongs to the broader class of A28 antigens, so this could also be reported as A69(28) or simply as A69. Not all serological types have broader classes though. For example, A2 does not have a broader class, therefore it is never followed by a bracket. **Figure 5** shows how serological typing with broad antigens could look when converted into molecular typing.



**Figure 23. Dropdown with options for entering serological HLA information (left), and dropdown results after typing information (right)**

When entering HLA antigens at a specific locus they go into fields 1 and 2 (**Figure 21**). It does not matter if they are entered in the order they are shown on the typing report. For heterozygous HLA loci (i.e. the HLA antigens are different at a specific locus), you will see two HLA types in the results, e.g. A2, A24 and both should be entered into the EBMT Registry (**Figures 24 and 25**). Where only one result is reported for a certain locus e.g. DQ2 (possible homozygous), you should enter the reported result under the first antigen. For the second antigen, use the code ‘only one value reported’ (**Figures 24 and 25**). This is important because if you leave the second HLA type empty, it is not clear if the typing was homozygous or if the insertion of the second antigen was forgotten.



**Figure 24. Examples of homozygous and heterozygous HLA types on a serological HLA report**

**Figure 25. Entry of heterozygous and homozygous serological HLA types into the EBMT Registry (using HLA typing in Figure 24. The blue border indicates homozygous HLA and the red border indicates heterozygous HLA)**

If results have not been provided by the laboratory for a certain locus (both antigens), please select 'Not evaluated'. This becomes available to select when you click on the three dots to the right-hand side of the field (**Figure 26**). This is important because if you leave fields for that locus empty, it is not clear if the typing has not been provided by the laboratory or if the insertion of the typing was forgotten for this locus.

**Patient HLA serology**

---

Serology HLA typing done  No  Yes

HLA A: serology in the patient antigen 1

HLA A: serology in the patient antigen 2

Mark as 'Not evaluated'

**Figure 26. Instruction on how to mark a serological antigen field as not evaluated**

**Figure 27** shows an example of a serological typing report and how this should be correctly entered into the EBMT Registry (**Figure 28**). The different loci have been colour coded to make visual mapping of data easier.

Interpreted HLA Class I type (serological equivalent)  
A2 B7; Bw6; Cw7  
 Interpreted HLA Class II type (serological equivalent)  
DR7, DR15(DR2) DQ2, DQ6(DQ1) DR51, DR53

**Figure 27. An example serological typing report** (image has been colour coded for easy mapping to Figure 28)

Serology HLA typing done  No  Yes

HLA A: serology in the patient antigen 1 A2 HLA A: serology in the patient antigen 2 Only one value reported	HLA DRB1: serology in the patient antigen 1 DR7 HLA DRB1: serology in the patient antigen 2 DR15(2)
HLA B: serology in the patient antigen 1 B7 HLA B: serology in the patient antigen 2 Only one value reported	HLA DQB1: serology in the patient antigen 1 DQ2 HLA DQB1: serology in the patient antigen 2 DQ6(1)
HLA C: serology in the patient antigen 1 Cw7 HLA C: serology in the patient antigen 2 Only one value reported	HLA DPB1: serology in the patient antigen 1 Not evaluated ∅ HLA DPB1: serology in the patient antigen 2 Not evaluated ∅

**Figure 28. Entry of serological HLA typing with heterozygous, homozygous and empty HLA fields in the EBMT Registry** (using HLA typing in Figure 27. Image has been colour coded to aid visual mapping)

## Donor HLA

The data entry for donor HLA is identical to the procedure for entering patient HLA (refer to pp. 6-22). It is not possible to copy the HLA information from the patient fields to the donor fields, even if the donor and patient HLA are identical. This measure is taken because, in some instances, the donors are wrongly classified as being identical to the patient, even though there are mismatches present.

## Number of HLA mismatches

In the Allo HCT Day 0 DCF Donor & Graft Information section, you will be asked to report the number of allelic or antigenic mismatches between patient and donor. When molecular HLA typing has been performed, you only need to complete the number of allelic mismatches. When serological typing has been performed, you are only to complete the number of antigen mismatches. If you have entered a combination of allelic and antigenic HLA typing, you will need to complete the number of mismatches in both sections. This is indicated clearly on the Allo HCT Day 0 DCF in the relevant sections (**Figure 29**).

**\*Method used for patient/donor HLA typing:**  Molecular  
(select all that apply)  Serology

**if molecular typing was done:**

*Locus:	*Number of mismatches, allelic:			
A:	<input type="checkbox"/> 0 (match)	<input type="checkbox"/> 1	<input type="checkbox"/> 2	<input type="checkbox"/> Not evaluated
B:	<input type="checkbox"/> 0 (match)	<input type="checkbox"/> 1	<input type="checkbox"/> 2	<input type="checkbox"/> Not evaluated
C:	<input type="checkbox"/> 0 (match)	<input type="checkbox"/> 1	<input type="checkbox"/> 2	<input type="checkbox"/> Not evaluated
DRB1:	<input type="checkbox"/> 0 (match)	<input type="checkbox"/> 1	<input type="checkbox"/> 2	<input type="checkbox"/> Not evaluated
DQB1:	<input type="checkbox"/> 0 (match)	<input type="checkbox"/> 1	<input type="checkbox"/> 2	<input type="checkbox"/> Not evaluated
DPB1:	<input type="checkbox"/> 0 (match)	<input type="checkbox"/> 1	<input type="checkbox"/> 2	<input type="checkbox"/> Not evaluated

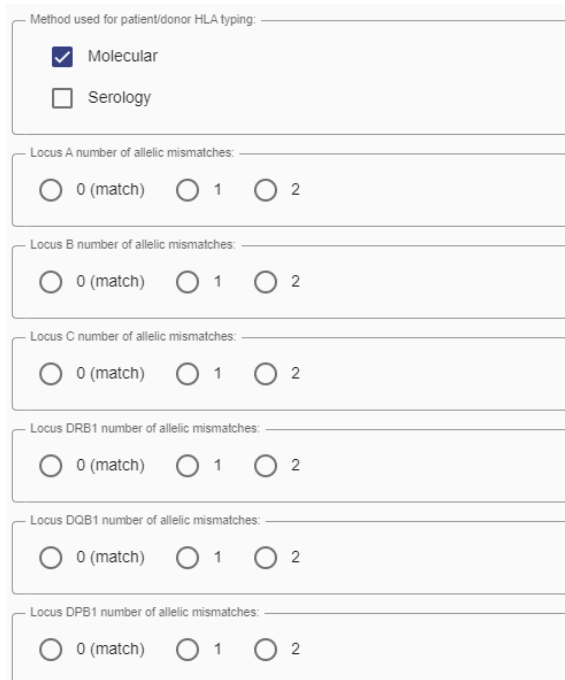
**if serological typing was done:**

*Locus:	*Number of mismatches, antigenic:			
A:	<input type="checkbox"/> 0 (match)	<input type="checkbox"/> 1	<input type="checkbox"/> 2	<input type="checkbox"/> Not evaluated
B:	<input type="checkbox"/> 0 (match)	<input type="checkbox"/> 1	<input type="checkbox"/> 2	<input type="checkbox"/> Not evaluated
C:	<input type="checkbox"/> 0 (match)	<input type="checkbox"/> 1	<input type="checkbox"/> 2	<input type="checkbox"/> Not evaluated
DRB1:	<input type="checkbox"/> 0 (match)	<input type="checkbox"/> 1	<input type="checkbox"/> 2	<input type="checkbox"/> Not evaluated
DQB1:	<input type="checkbox"/> 0 (match)	<input type="checkbox"/> 1	<input type="checkbox"/> 2	<input type="checkbox"/> Not evaluated
DPB1:	<input type="checkbox"/> 0 (match)	<input type="checkbox"/> 1	<input type="checkbox"/> 2	<input type="checkbox"/> Not evaluated

**Figure 29. Allo HCT Day 0 DCF Donor & Graft information section – allelic and antigenic mismatches**

### Molecular HLA: number of allelic mismatches

Report 0 mismatches at a given locus when both patient and donor alleles are identical. If you were to look at a single patient allele at a specific locus, the first and second fields would match to a single donor allele at the same locus. This would be the first match, and the order in which these alleles are presented on a typing report at a specific locus within the patient and donor sections will not affect the match outcome. When you then compare the other patient allele at the same locus to the other donor allele at the same locus, their first and second fields would also match, giving the second match. This would be reported as 0 mismatches, and you select the option “0 (match)” on the Allo HCT Day 0 DCF in the molecular matching section. **Figure 30** shows the allelic mismatch fields in the EBMT Registry and **Figure 31** shows an example patient and donor molecular typing which has 0 mismatches at each HLA Locus. The different loci have been colour coded to make visual mapping of data easier.



Method used for patient/donor HLA typing: \_\_\_\_\_

Molecular

Serology

---

Locus A number of allelic mismatches: \_\_\_\_\_

0 (match)    1    2

---

Locus B number of allelic mismatches: \_\_\_\_\_

0 (match)    1    2

---

Locus C number of allelic mismatches: \_\_\_\_\_

0 (match)    1    2

---

Locus DRB1 number of allelic mismatches: \_\_\_\_\_

0 (match)    1    2

---

Locus DQB1 number of allelic mismatches: \_\_\_\_\_

0 (match)    1    2

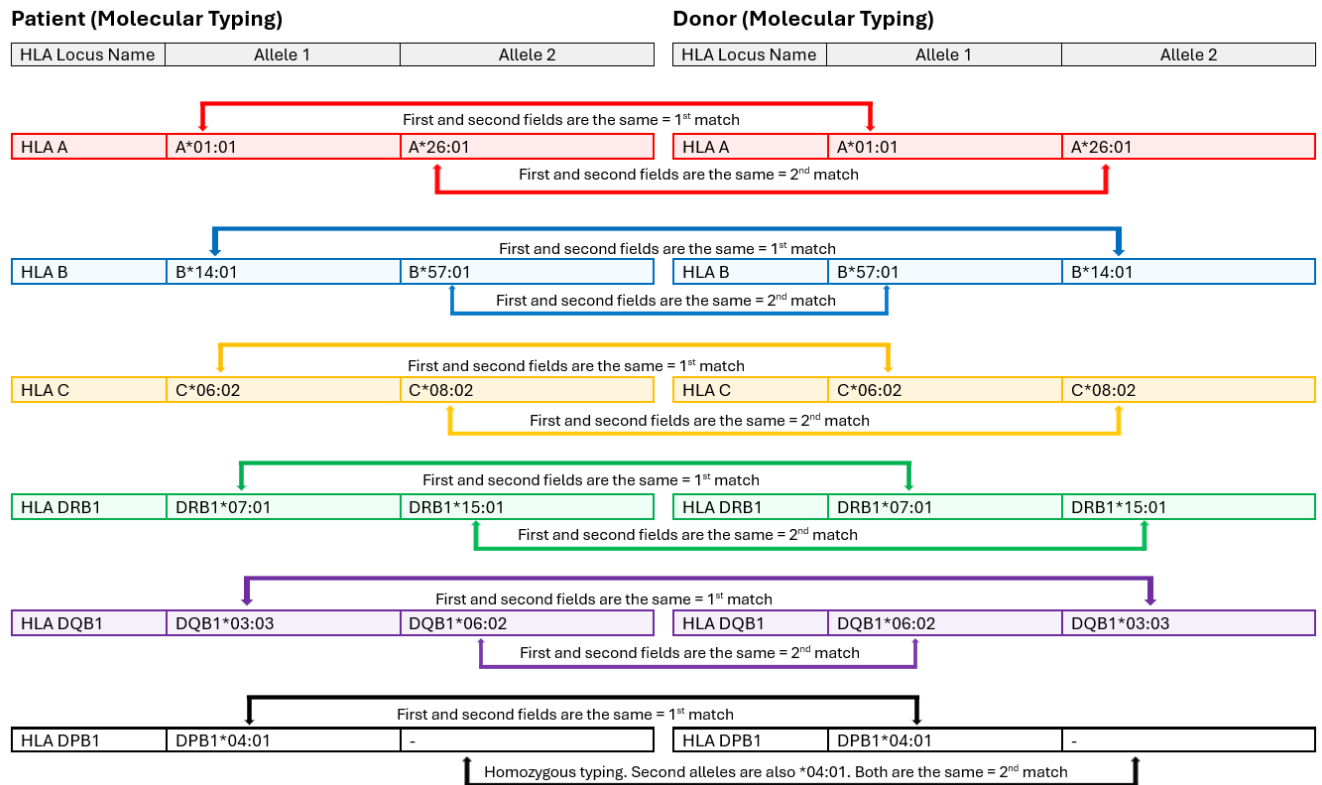
---

Locus DPB1 number of allelic mismatches: \_\_\_\_\_

0 (match)    1    2

**Figure 30. Allelic mismatch fields in the EBMT Registry**

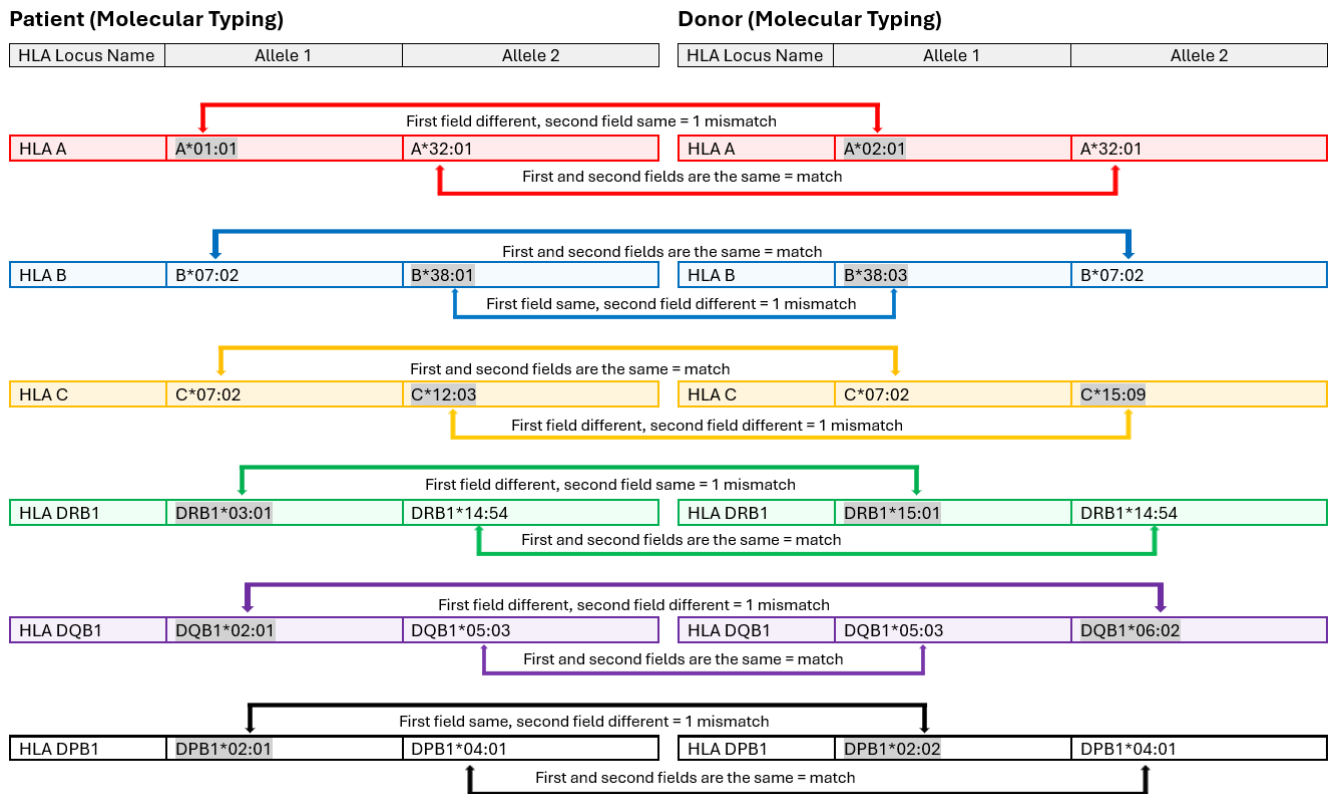




**Figure 31. Example patient and donor molecular typing which has 0 mismatches at each HLA locus (image has been colour coded to aid visual mapping)**

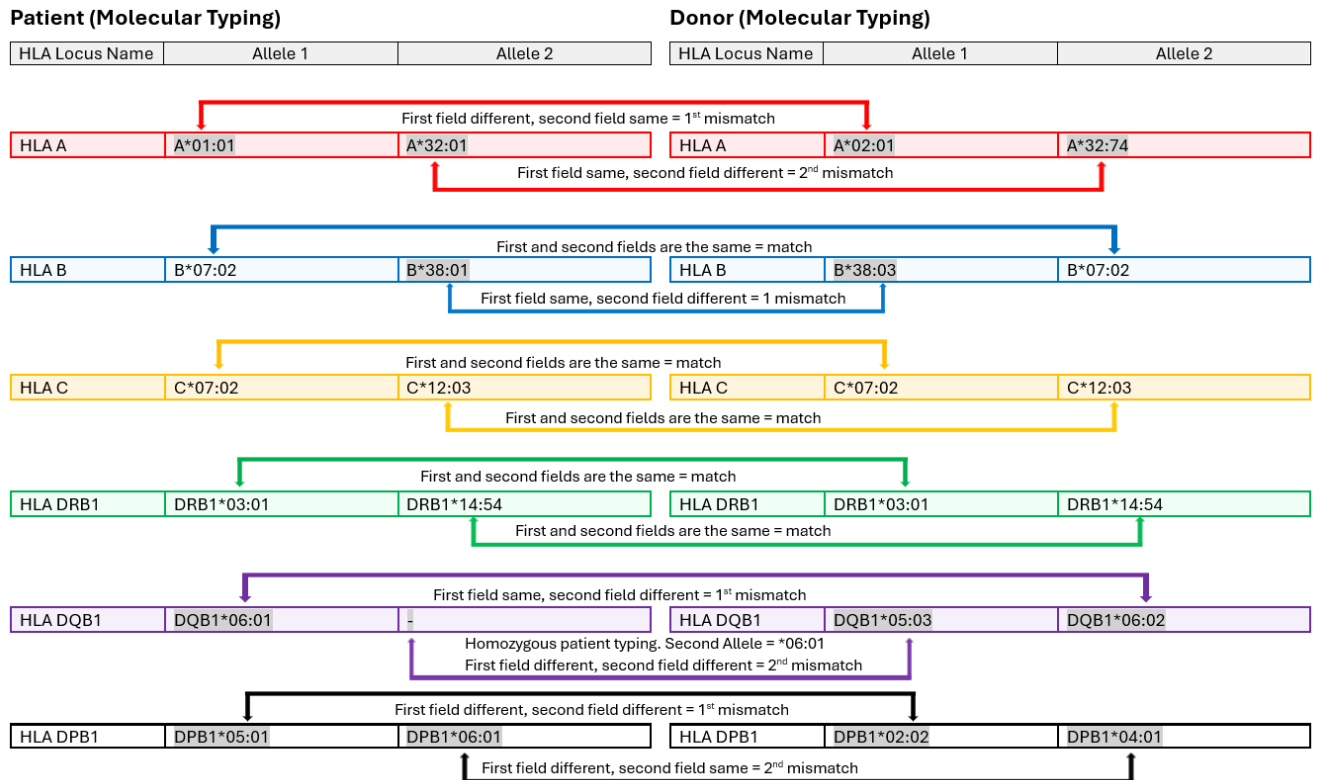
You do not need to consider the information held in the third or fourth fields of the HLA type for matching purposes, unless an allele has the suffix “N” (**Figure 3**) for either the patient or donor. This is to be recorded as a mismatch even if the first and second fields for a given locus match between patient and donor.

Report 1 mismatch at a given locus when one allele of the patient has differences in the first and/or second field when compared to the donor’s, but the other allele at the same locus is identical. You select option “1” on the Allo HCT Day0 DCF in the molecular matching section. The order in which these alleles are presented on a typing report at a specific locus within the patient and donor section will not affect the match outcome. **Figure 32** shows example patient and donor molecular typing which has 1 mismatch at each HLA Locus. The different loci have been colour coded to make visual mapping of data easier. If this was a related sibling donor then we would say they were a haplo match with the patient.



**Figure 32. Example patient and donor molecular typing with 1 mismatch at each HLA locus**  
(image has been colour coded to aid visual mapping)

Report 2 mismatches at a given locus when neither allele of the patient matches in the first and/or second fields with either of the donor’s alleles. You select option “2” on the Allo HCT Day 0 DCF in the molecular matching section. The order in which these alleles are presented on a typing report at a specific locus will not affect the match outcome. **Figure 33** shows example patient and donor molecular typing which has different degrees of mismatching at each HLA locus (0 mismatches, 1 mismatch and 2 mismatches). The different loci have been colour coded to make visual mapping of data easier. You would not want to proceed to transplant with this donor!



**Figure 33. Example patient and donor molecular typing with different degrees of mismatching at each HLA locus (0 mismatches, 1 mismatch and 2 mismatches) (image has been colour coded to aid visual mapping)**

Figure 34 shows how to record the allelic mismatches from Figure 33 in the EBMT Registry.

Locus A number of allelic mismatches:  0 (match)  1  2

Locus B number of allelic mismatches:  0 (match)  1  2

Locus C number of allelic mismatches:  0 (match)  1  2

Locus DRB1 number of allelic mismatches:  0 (match)  1  2

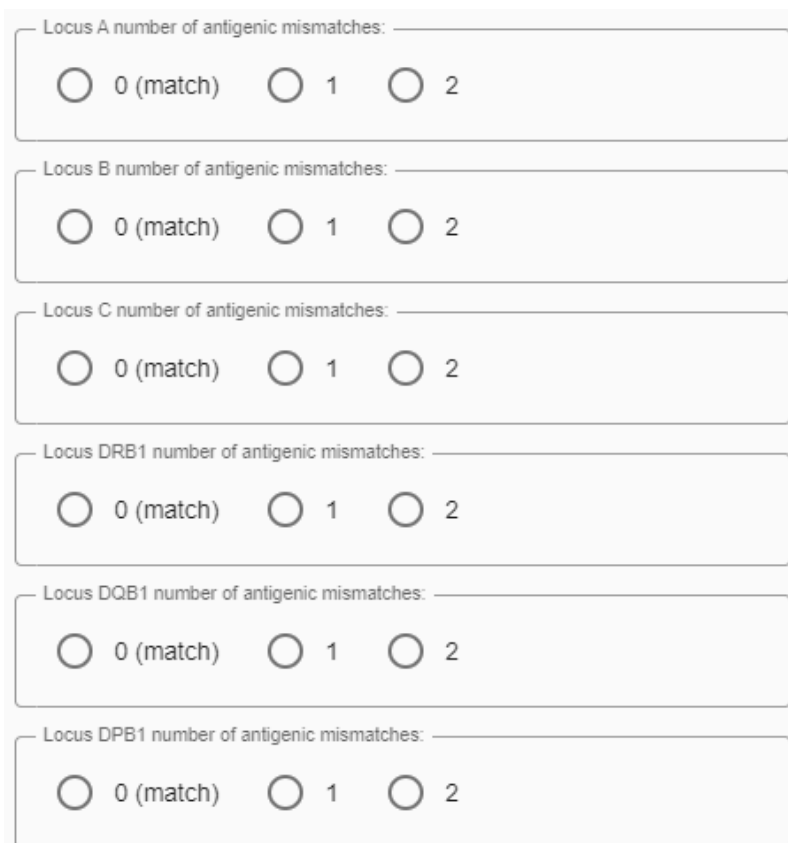
Locus DQB1 number of allelic mismatches:  0 (match)  1  2

Locus DPB1 number of allelic mismatches:  0 (match)  1  2

**Figure 34. Recording of allelic mismatches in the EBMT Registry (using Figure 33 as an example)**

### Serological HLA: number of antigen mismatches

Report 0 mismatches at a given locus when both antigens (i.e. the number after the locus designation) are identical between patient and donor. If you were to look at a single patient antigen at a specific locus this would match to a single donor antigen at the same locus. This would be the first match, and the order in which these antigens are presented on a typing report at a specific locus will not affect the match outcome. When you then compare the other patient antigen at the same locus to the other donor antigen at the same locus this would also match, giving the second match. This would be reported as 0 mismatches, and you select the option “0 (match)” on the Allo HCT Day 0 DCF in the serological section. **Figure 35** shows the antigen mismatch fields in the EBMT Registry and **Figure 36** shows example patient and donor serological typing which has 0 mismatches at each HLA Locus. The different loci have been colour coded to make visual mapping of data easier.



Locus A number of antigenic mismatches:  0 (match)  1  2

Locus B number of antigenic mismatches:  0 (match)  1  2

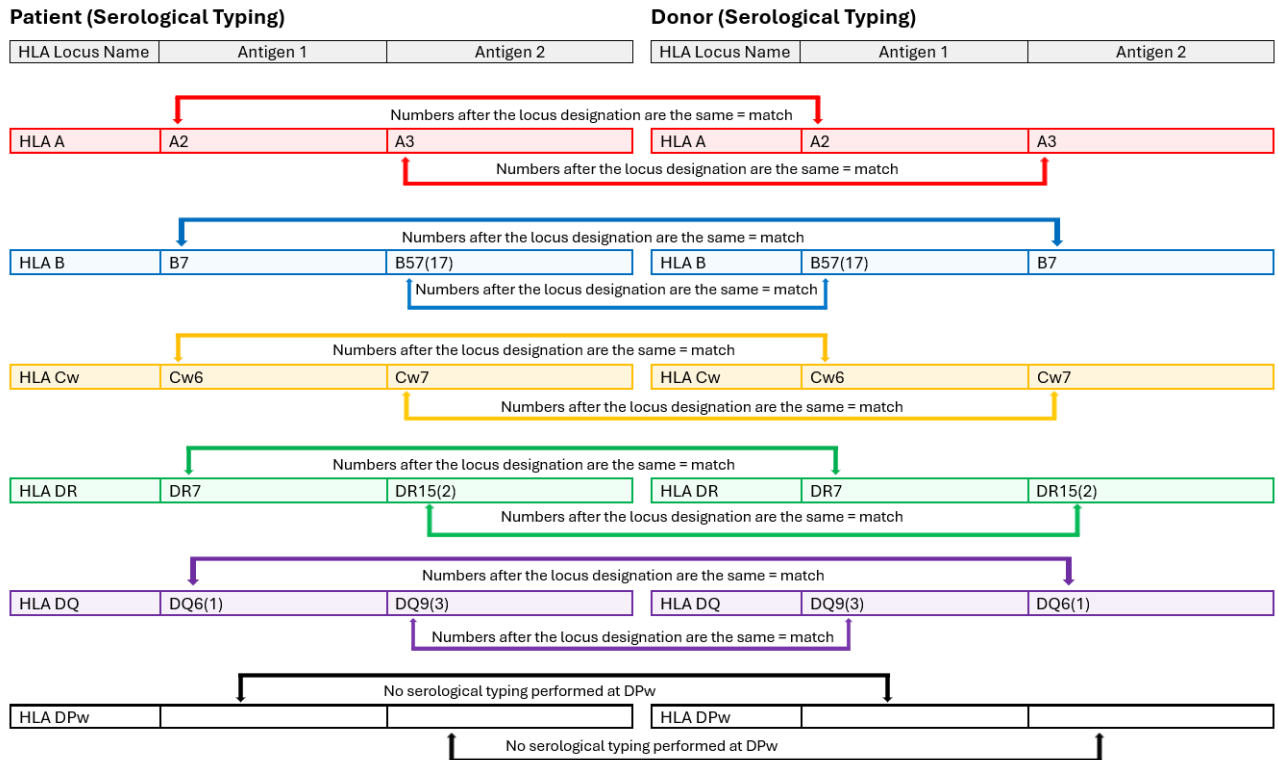
Locus C number of antigenic mismatches:  0 (match)  1  2

Locus DRB1 number of antigenic mismatches:  0 (match)  1  2

Locus DQB1 number of antigenic mismatches:  0 (match)  1  2

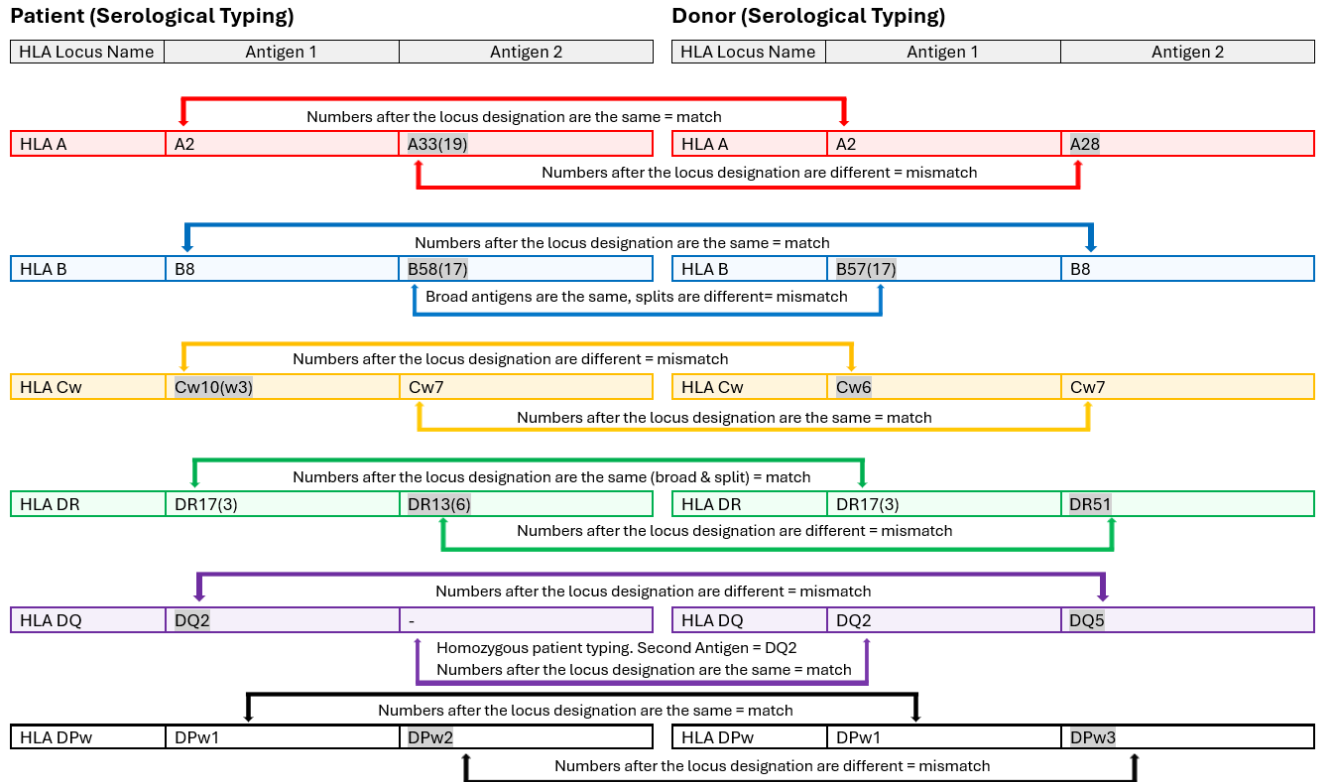
Locus DPB1 number of antigenic mismatches:  0 (match)  1  2

**Figure 35. Antigen mismatch fields in the EBMT Registry**



**Figure 36. Example patient and donor serological typing which has 0 mismatches at each HLA locus**  
(image has been colour coded to aid visual mapping)

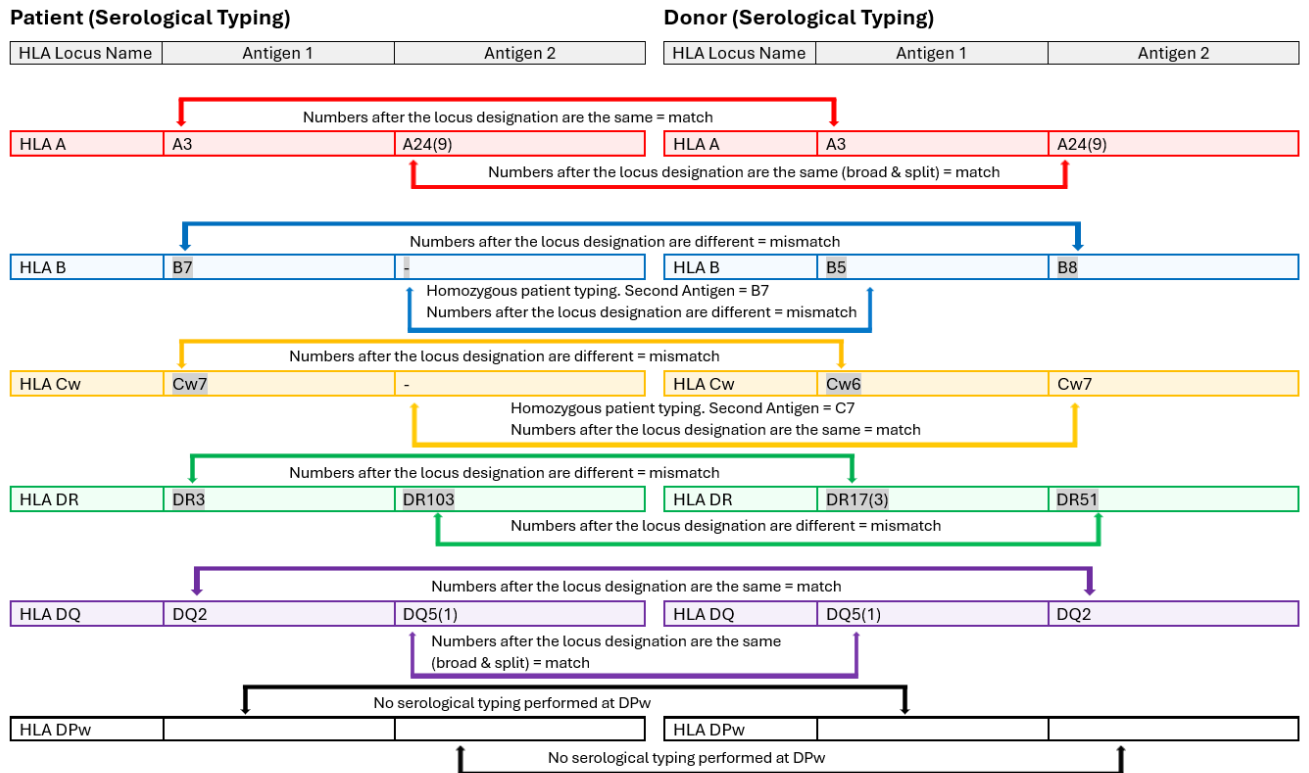
Report 1 mismatch at a given locus when one antigen of the patient doesn't match with either of the donor's antigens, but the other patient antigen does. You select option "1" on the Allo HCT Day 0 DCF in the serological matching section. It is still a mismatch when the broad antigen at a given locus for patient and donor match (number in parentheses (brackets)) but the specific antigen split does not. The order in which these antigens are presented on a typing report at a specific locus will not affect the match outcome. **Figure 37** shows example patient and donor serological typing which has 1 mismatch at each HLA Locus. The different loci have been colour coded to make visual mapping of data easier. If this was a related sibling donor then we would say they were a haplo match with the patient.



**Figure 37. Example patient and donor serological typing with 1 mismatch at each HLA locus.**

(image has been colour coded to aid visual mapping)

Report 2 mismatches at a given locus when neither of the patient (recipient) antigens match with either of the donor’s antigens. You select option “2” on the Allo HCT Day 0 DCF in the serological matching section. The order in which these antigens are presented on a typing report at a specific locus will not affect the match outcome. **Figure 38** shows example patient and donor serological typing which has different degrees of mismatching at each HLA locus (0 mismatches, 1 mismatch and 2 mismatches). The different loci have been colour coded to make visual mapping of data easier. This would not be a good donor for transplant.



**Figure 38. Example patient and donor serological typing with different degrees of mismatching at each HLA locus (0 mismatches, 1 mismatch and 2 mismatches) (image has been colour coded to aid visual mapping)**

**Figure 39** shows how to record the antigen mismatches from **Figure 38** in the EBMT Registry.

Locus A number of allelic mismatches:  0 (match)  1  2

Locus B number of allelic mismatches:  0 (match)  1  2

Locus C number of allelic mismatches:  0 (match)  1  2

Locus DRB1 number of allelic mismatches:  0 (match)  1  2

Locus DQB1 number of allelic mismatches:  0 (match)  1  2

Locus DPB1 number of allelic mismatches:  0 (match)  1  2

Not evaluated

**Figure 39. Recording of antigen mismatches in the EBMT Registry (using Figure 38 as an example)**

## Important considerations

Entering HLA data has to be done meticulously, as it's used to classify patient-donor pairs as fully-matched, mismatched or haplo identical and has implications for how these patients are analysed in clinical studies. Incorrect HLA typing data could lead to wrong conclusions.

To prevent incorrect HLA data being entered, please do the following:

- Carefully check that you are entering the patient HLA in the patient fields, and the donor HLA in the donor fields. These must be entered into their corresponding Registry fields for correct analysis.
- Double-check that you entered the HLA typing of the donor who was used for the transplant. Sometimes HLA typing reports will list several donors considered for the transplant and you must carefully check the IDs of each to make sure you are entering the details of the one selected for the transplant.
- Be careful with the order in which HLA typing results appear on the HLA report returned by the laboratory. They might be in a different order to the HLA fields in the EBMT Registry or they may not have all the HLA loci listed.
- Provide full details of the available HLA data and do not truncate it (i.e. all fields provided and the highest typing resolution available). The level of detail is what makes the HLA data useful for research.

You may find it useful to highlight all relevant parts on the HLA report so that you can carefully and accurately cross-check data and don't enter irrelevant or the wrong information by accident.



## Useful links

HLA allele database:

<https://www.ebi.ac.uk/ipd/imgt/hla/>

Full list of alleles or MAC:

<https://www.ebi.ac.uk/ipd/imgt/hla/alleles/>

<https://hml.nmdp.org/MacUI/>

Full list and meaning of suffixes:

[https://hla.alleles.org/pages/wmda/p\\_groups/](https://hla.alleles.org/pages/wmda/p_groups/)

[https://hla.alleles.org/pages/wmda/g\\_groups/](https://hla.alleles.org/pages/wmda/g_groups/)

<https://hla.alleles.org/nomenclature/naming.html>

Other useful links:

[https://hla.alleles.org/pages/misc\\_lists/](https://hla.alleles.org/pages/misc_lists/)

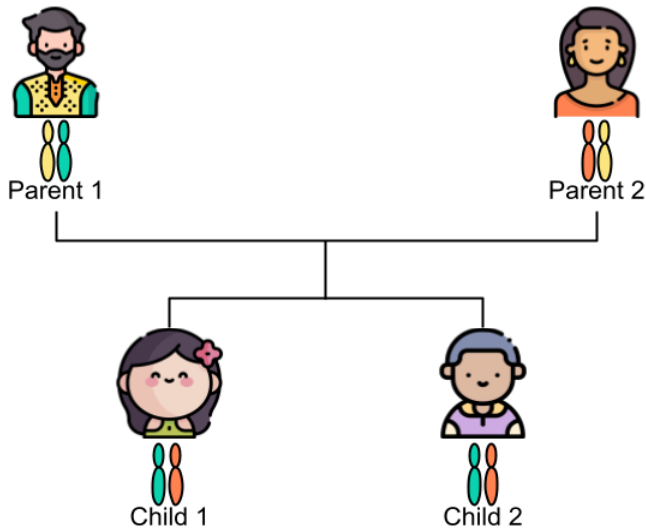
## References

1. Total Number of Donors and Cord blood units [Internet]. Wmda.info. [cited 2024 Aug 22]. Available from: <https://statistics.wmda.info>
2. Wang Y, Xu S, Fang P. Impact of HLA-DPB1 Matching on Outcome of Unrelated Transplant for Hematologic Malignant Diseases: A Systematic Review and Meta-analysis. *Transplantation Proceedings*. 2019 Jul;51(6):1982-9.

## Appendix A - Inheritance genetics schema

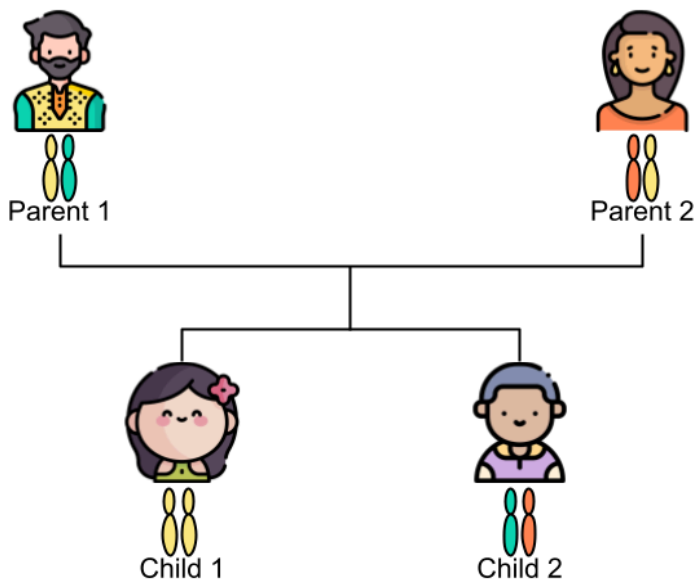
In this appendix the odds of matching with a sibling are explained using schemas.

### Example 1



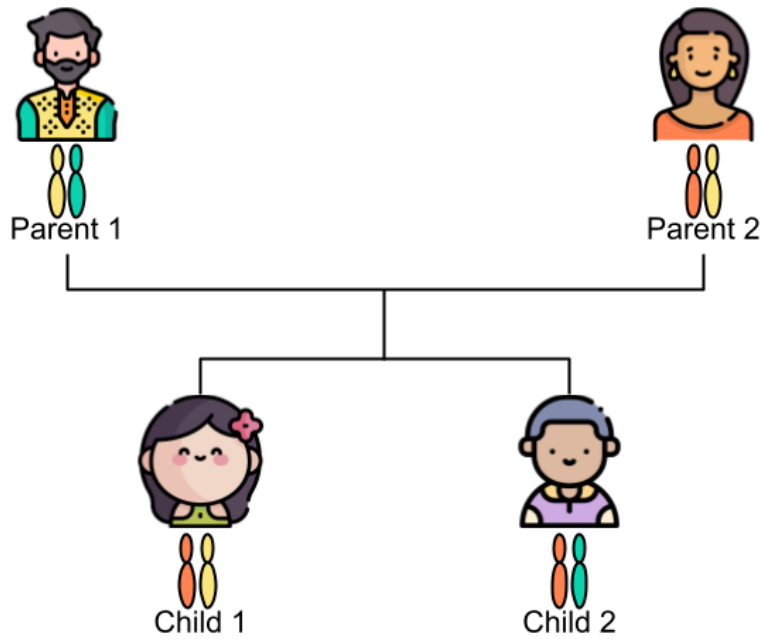
In this example, child 1 and child 2 are haploidentical siblings. Child 1 can be a haplo donor to child 2 and vice versa. There is a 25% chance of this happening.

### Example 2



In this example, child 1 and child 2 are not matching siblings. They inherited different genes from their parents, so their haplotypes are different. There is a 25% chance of this happening.

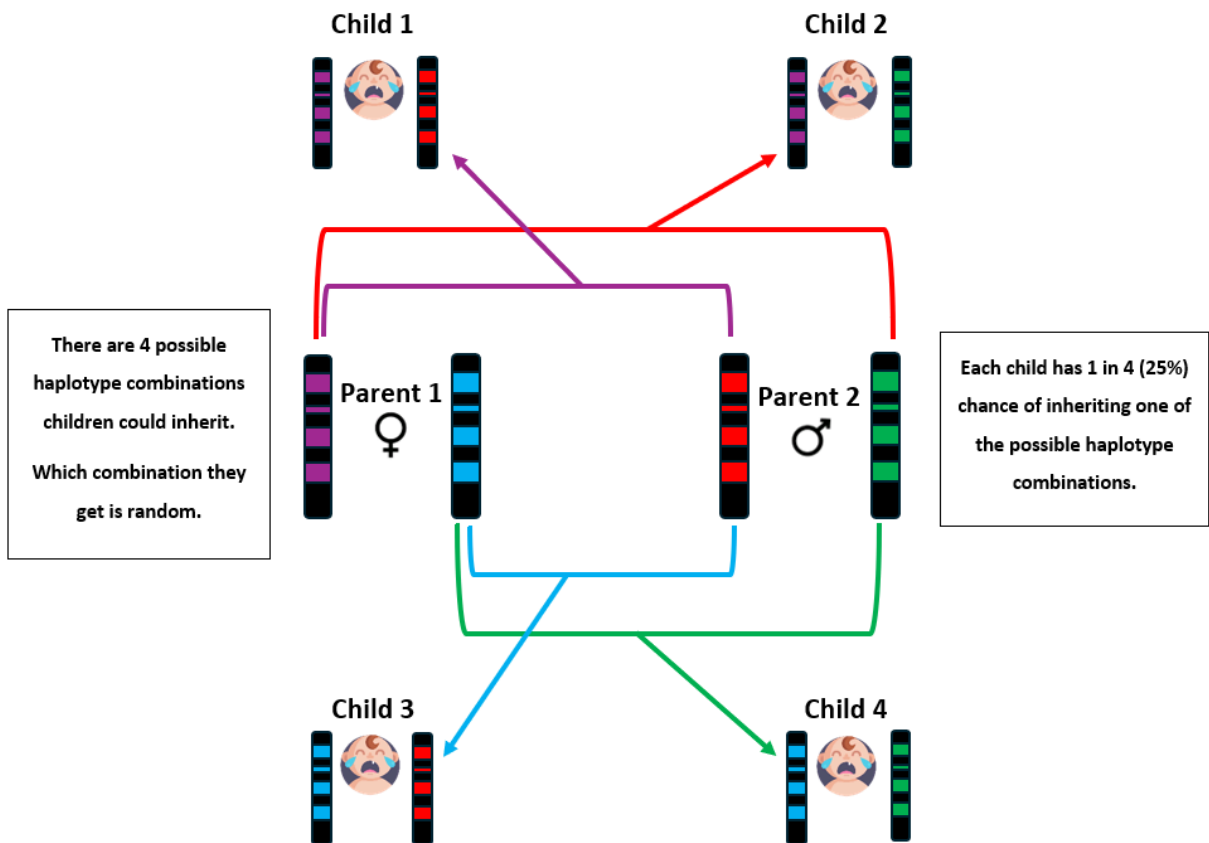
Example 3



In this example, child 1 and child 2 are partially matching siblings. They inherited different haplotypes from their father, but the same orange haplotype from the mother. There is a 50% chance of this happening.

In the examples on the next pages, Punnet squares are used to go further into the explanation of the odds of matching with a sibling.

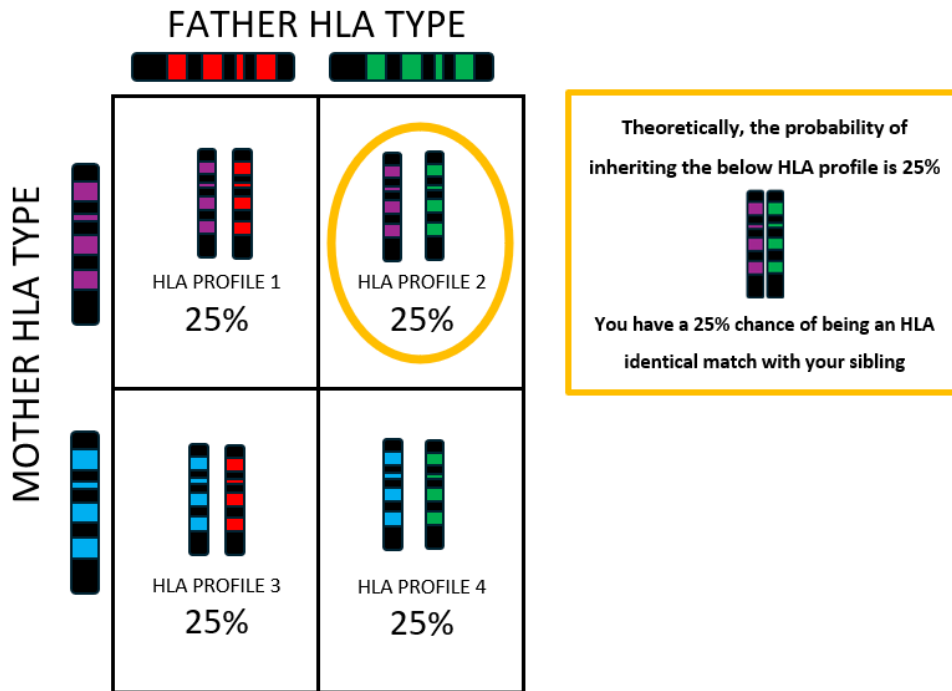
A Punnet square is a grid diagram devised in 1905 by an English geneticist named Reginald Punnet. It serves as a technique to calculate mathematical probability of inheriting particular genotypes. It is a simple graphical way to show all potential combinations of genotypes that can occur in offspring, when the parental genotypes are known (to learn more about Punnet squares consult [https://en.wikipedia.org/wiki/Punnett\\_square](https://en.wikipedia.org/wiki/Punnett_square)).



The examples which follow, will help you understand how HLA matching probability is calculated using Punnet squares.

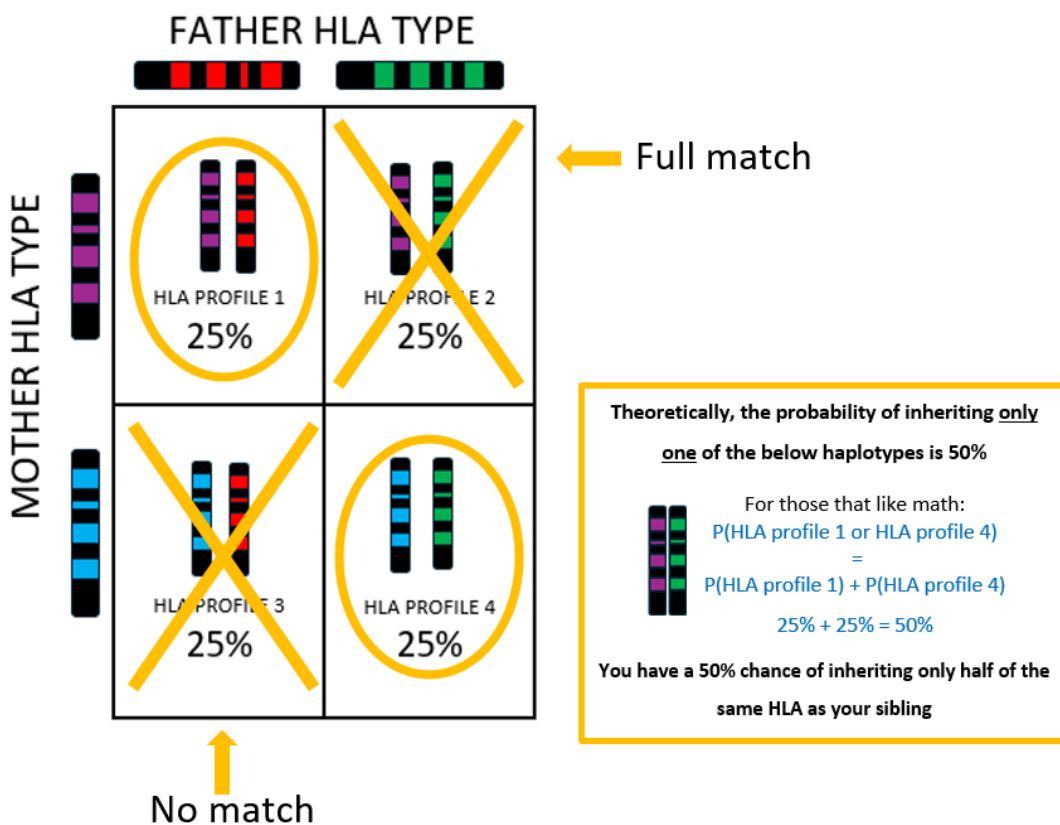
Example 4

A Punnet square is used to show the probability of a biological sibling being HLA identical.



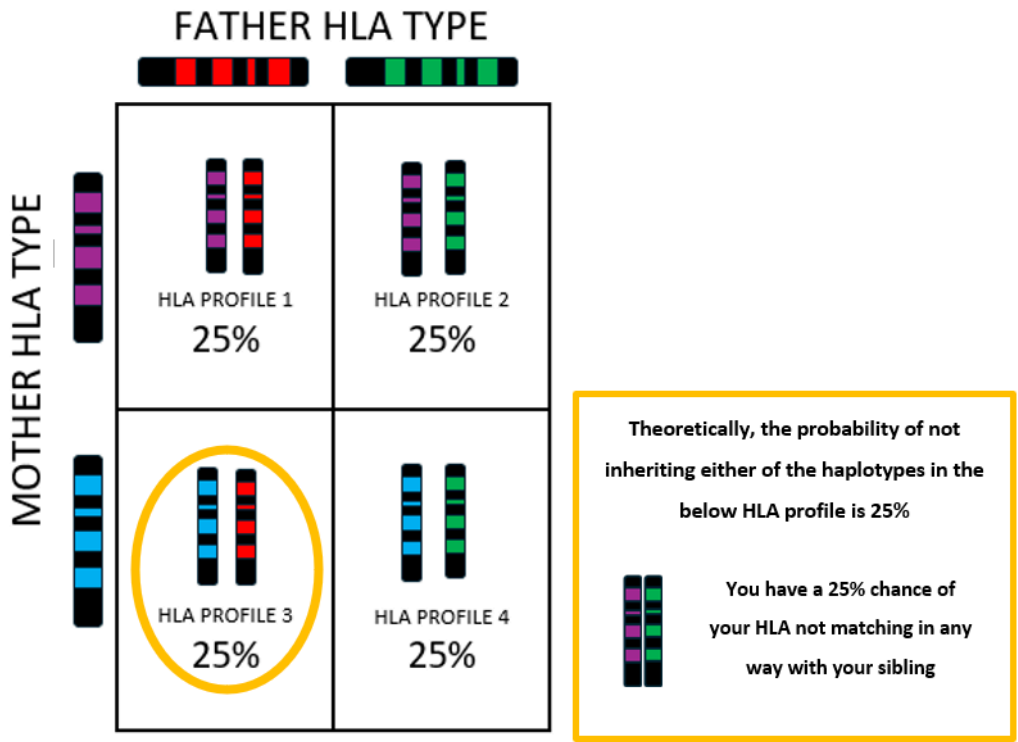
Example 5

A Punnet square is used to show the probability of a biological sibling being haploidentical.



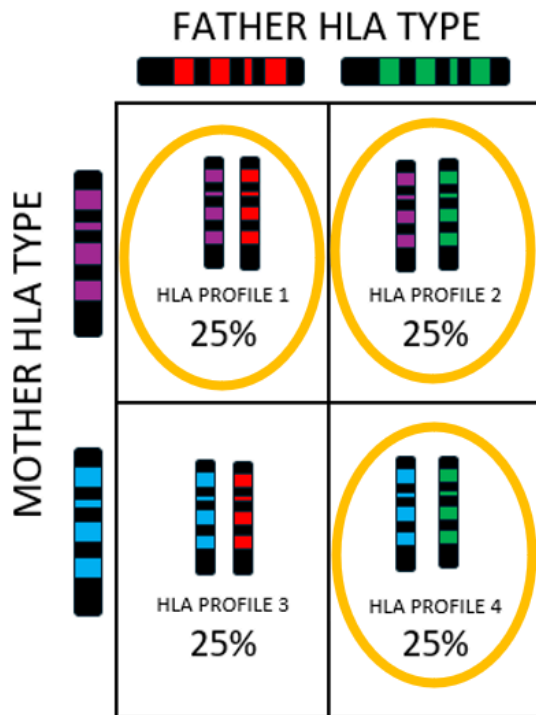
Example 6

A Punnet square is used to show the probability of a biological sibling not matching on HLA.



Example 7

A Punnet square is used to show the probability of a biological sibling being either haploidentical or fully matched.



Theoretically, the probability of inheriting at least one of the below haplotypes is 75%

For those that like math:  
 $P(\text{HLA profile 1 or HLA profile 2 or HLA profile 4})$   
 $=$   
 $P(\text{HLA profile 1}) + P(\text{HLA profile 2}) + P(\text{HLA profile 4})$   
 $25\% + 25\% + 25\% = 75\%$

**You have a 75% chance of your HLA having at least one haplotype match with your sibling.**  
**If you have siblings that's pretty good odds!**

## Glossary of HLA-related terms

Term	Definition
10/10 match	On 5 important HLA loci both alleles match between patient and donor: HLA-A, -B, -C, -DRB1, -DQB1
12/12 match	On 6 important HLA loci both alleles match between patient and donor: HLA-A, -B, -C, -DRB1, -DQB1, -DPB1
8/8 match	On 4 important HLA loci both alleles match between patient and donor: HLA-A, -B, -C, -DRB1
Allele	Genes that code for the transmission of traits, of which you always inherit at least one from each biological parent. Specifically different versions of the same gene that are in the same location (locus) on a particular chromosome and control the same trait (see gene and trait).
Allogeneic HCT	A stem cell transplantation where healthy donor stem cells are infused into a recipient after the recipient's stem cells have been destroyed by treatment (radiation and/or chemotherapy). This procedure aims to replace the recipient's stem cells, which are not working the way they should and cause illness.
Alloreactivity	Where a strong immune response can be generated against foreign molecules which have not previously been encountered. In the context of HLA it's where there is a strong primary T-cell response against allelic variants of the major histocompatibility complex.
Anti-thymocyte globulin (ATG)	ATG is a medicine made of antibodies (derived from horses or rabbits), that suppresses the immune system within the body (in-vivo) for a short period of time. It specifically targets and destroys human T-lymphocytes (T-cells) and their precursors. Due to this mechanism of action, it helps reduce allogeneic HCT complications of GvHD and graft rejection. However, overuse of ATG can put a recipient at risk of infection, cytotoxicity or lymphoma.
Antibodies	Protective proteins produced by the body's immune system to neutralise harmful antigens, to prevent illness in the body (see antigen)
Antigen	Protein markers on cells that trigger an immune response in the body.
Assay	Laboratory test to check contents of a sample (in the HLA context this is screening of a blood or saliva sample to identify antibodies and antigens for matching purposes)
Broad antigens	Antigens with crude measures of specificity. The serology test was unable to detect different antigens due to cross-reactivity and instead of being distinguished from each other were assigned as the same. When further analysed at the DNA level these antigens can be split into distinguishable types (see also split antigens)



Chromosome	The part of a cell in the body where DNA that encodes genes is stored. It is thread-like and can be found in the nucleus (core) of a cell
Class I HLA antigens	Antigens that are presented on the outside of most cells in the body, that can show if a disease is present in the cell. Also known as Major Histocompatibility Complex (MHC) class I. The class I antigens important in HLA matching are HLA-A, HLA-B and HLA-C
Class II HLA antigens	Antigens that are presented on the outside of certain immune cells (such as macrophages and dendritic cells). These cells are important in initiating immune responses. Also known as Major Histocompatibility Complex (MHC) class II. The class II antigens important in HLA matching are HLA-DRB1, HLA-DQB1 and HLA-DPB1
Cross-reactivity (of antigens)	When different antigens have the same reaction with the same antibody, so the serology test confuses one antigen for another (see antibody, antigen)
Cytotoxicity	How toxic a substance is to cells
DNA	Full name: deoxyribonucleic acid. DNA is a long chain of molecules (nucleotides) found in the nucleus (core) of cells, that contains all the genetic information responsible for the development and function of an organism. DNA is organised into small segments called genes and each gene contains the instructions to make a specific product (usually a protein). DNA make up genes which make up chromosomes
DNA-based methods (for HLA typing)	A way to test a person's DNA, to accurately see if they are an HLA match to someone. These methods work at the DNA level and look to identify the genetic make-up of the HLA genes. Also referred to as molecular typing.
Engraftment	The process by which transplanted hematopoietic stem cells make their way (homing) through blood to the bone marrow where they have the optimal conditions to survive and proliferate making new blood and immune system cells
Ex-vivo	Outside of the body/outside of the living (e.g. cell manipulation in a laboratory, like in CAR-T)
Family studies	The process of testing family members to find a matching related donor for a recipient
Full match	A donor whose HLA matches the recipient's on at least 56 important HLA loci (HLA-A, -B, -C, -DRB1, -DQB1, -DPB1). Note: this is the European definition
Gene	A bit of DNA that is the starter for a specific process in our body. The basic unit of inheritance passed from parents to offspring. It is a segment of DNA which contains a sequence of instructions to specify physical and biological traits. Genes vary in size and function and are arranged one after the other to form chromosomes. They can code for specific proteins (which dictate cell function), control cell growth and division, control other genes and repair DNA damage.

	Typically organisms that reproduce sexually have two copies of each gene (one inherited from each parent)
Genetic identity (genotypic identity)	The pattern of genetic material that makes a person unique. In the context of a haplotypes it is the haplotypes inherited which make the person unique HLA wise.
Genotype	Set of genes that an organism has.
Graft	Living tissue that is transplanted into another person's body. In the context of HCT it is stem cells taken from a donor (via peripheral blood/bone marrow/cord blood) and transplanted into another person's body (the recipient) with the aim to replace their stem cells.
Graft failure	Engraftment of hematopoietic stem cells fails. This can be primary (no initial engraftment) or secondary (loss of donor cells after initial engraftment).
Graft rejection	Residual cells of the recipient's immune system (mainly T-cells) reject and attack the transplanted hematopoietic stem cells. It is an immune-mediated expulsion of an allogeneic graft. This term is only relevant to allogeneic transplants and is very specific.
GvHD	Graft-versus-host disease is a severe and potentially life threatening complication that can happen after an hematopoietic stem cell transplantation. The immune cells from the transplanted donor's tissue (the graft) attack the recipient's (host) cells within the body as they are identified as foreign.
Haplo donor (haploidentical donor)	A donor whose HLA is half matched to the recipients because only 1 matching haplotype was inherited along the common inheritance pathway. This is usually the parent, child or sibling.
Haploidentical	An exact match of the selection of genes that were inherited from a parent. The familial donor and recipient have just 1 identical HLA haplotype through inheritance
Haplotype	A selection of genes that were inherited together from one parent. Haplotypes tend to be transmitted in their entirety over hundreds of generations because the alleles are near to each other on the chromosome, and recombinations between these variants are rare.
HCT	Hematopoietic Cell Transplant, where stem cells (derived from bone marrow, peripheral blood or umbilical cord blood) are intravenously infused into a recipient so they can replicate and produce healthy blood cells.
Heterozygous	Having two different versions of one gene. This occurs if biological parents pass on different genes to their child
High resolution results	Molecular HLA typing which is able to establish HLA types at allele-level, where at minimum the first and second fields after the asterisk (*) are given on the HLA nomenclature, e.g HLA-A*02:01, HLA-A*02:101:01:02N

HLA	Human Leukocyte Antigens (proteins). Leukocytes are also called white blood cells so HLA can also be termed as human white blood cell proteins. These antigens are used by your body to see which cells are its own and which are not
HLA ambiguity	When the specific allele cannot be defined during the sequencing process and there are several allele possibilities that could be correct. These possibilities are all written down and show as a string or list of alleles e.g. HLA-A*02:01/03/04/05/06/08 (see HLA string)
HLA field	A group of digits shown in the HLA-nomenclature and given a number based on the position after the asterisk (*). Each field is separated by a colon (:)
HLA markers	Proteins on the outside of cells that help the body identify which cells are its own (see also antigens, HLA proteins and HLA molecules)
HLA matching	The checking of HLA types of a recipient and donor to see if they match. The closer the match on at least 5 important HLA loci (HLA-A, -B, -C, -DRB1 and -DQB1). The closer the match, the better the donor cells would be accepted by the recipient and the lower the risk of complications after the transplant
HLA molecules	Proteins on the outside of cells that help the body identify which cells are its own (see also antigens, HLA proteins and HLA Markers)
HLA Nomenclature	A system developed to to name/describe each allele discovered
HLA proteins	Proteins on the outside of cells that help the body identify which cells are its own (see also antigens, HLA molecules and HLA markers)
HLA string	A list of alleles that need to be considered as the sequencing process could not define the specific allele e.g. HLA-A*02:01/03/04/05/06/08 (see HLA ambiguity)
HLA suffix	A single letter appearing at the very end of the HLA-nomenclature used to indicate changes in how the HLA protein is expressed (e.g. N=null allele and not expressed on the cell surface)
HLA typing	A procedure in which the HLA of a recipient and possible donors are tested to check if they match (this may be molecular or serological and the purpose is to identify HLA antigens and/or HLA alleles)
HLA typing report	The printed results of HLA typing (or HLA matching). It may contain all relevant HLA loci or only some of them.
Homozygous	Having two identical versions of one gene (allele). This occurs when biological parents pass on the same gene variation to their child
Immune system	A complex system of cells, tissues, organs and proteins in the body which work together and help to fight infections and disease and also protect the body's own cells. The immune system is the body's internal defence system protecting it from anything harmful.

Immunosuppression	Treatment to suppress (hold back) an immune response in the body. In the context of post-transplant immunosuppressive treatment (e.g. PTCY) this is given to reduce the frequency of acute and chronic graft versus host disease as well as non-relapse mortality. PTCY works by inducing alloreactive T-cell dysfunction and suppression.
In-vivo	In the body/within the living
Innate	Present in an individual from birth (naturally)
Level of match	The extent to which a recipient and donor are HLA compatible (how well a recipient and donor match)
Locus (loci)	The location of a gene on a chromosome
Low resolution results	HLA results with only 2 digits after the asterisk (*). This is typing that only gives antigen level results. Serological typing is always low resolution typing. Molecular typing is low resolution when when only the first field is shown after the asterisk (*) on the HLA nomenclature, e.g. HLA-A*02, DR12, DQ1
MAC (Multiple Allele Code)	A systemic and succinct coding system used to represent ambiguous HLA typing with allelic strings
Match (matching donor)	A donor whose HLA type is either fully matching the recipient's (as in the case of biological siblings) or who has at least a 10/10 (HLA-A, B, C, DRB1, and DQB1) match with the recipient (as in the case of unrelated donors)
Mismatch (mismatched donor)	A donor whose HLA type is not fully matching the recipient's on the following 5 HLA loci (HLA-A, B, C, DRB1, and DQB1). Note: this is the European standard
Molecular typing	Method of testing HLA, which can be recognised by the results having an asterisk (*) in them. This level of HLA typing is at the DNA level and looks to identify the genetic make-up of the HLA genes. Also referred to as DNA typing.
Optimal donor	A donor that will produce the best outcome with very little or no risk to the recipient. In the context of HLA it is a genetically related donor who is HLA identical to the patient (e.g. twin, sibling)
Pathogen	Any organism that can infect animals and plants (hosts) and cause disease (e.g. bacteria, viruses, parasites and fungi)
Permissible mismatch	Allele mismatches which are tolerated and have reduced risks after the transplants transplant.
Phenotype	An organism's observable and/or measurable characteristics (traits). The way a genotype is expressed and is seen. The phenotype can be influenced by the environment (e.g. ear lobes can vary in length, with some being long and some short. This could be down to genetics alone or a longer earlobe could be caused by constantly wearing heavy earrings which has stretched it over time).

Post-transplant cyclophosphamide (PTCY)	A drug (medicine) used to suppress the immune system, in this definition given after allogeneic HCT to reduce the frequency of acute and chronic graft versus host disease as well as non-relapse mortality. PTCY works by inducing alloreactive T-cell dysfunction and suppression.
Prophylaxis strategies	Measures taken to prevent the recipient's body from having a negative response to the donor cells. In the context of GvHD it is treatment given (drugs) when mismatched donors are used in allo-transplants to reduce or prevent the risk of GvHD. Prophylaxis drugs work by reducing the number of T-cells in the graft which will be responsible for causing GvHD.
Recipient	A person who is receiving stem cells from a donor
Reconstitution	The process of building something up again. In the context of HCT it is the process of rebuilding the immune system from transplanted hematopoietic stem cells
Relapse	The return of a disease after a period of improvement or apparent full recovery
Related donor	A donor that is genetically related to the recipient (for example a parent or sibling)
Serological typing	A way to test a person's match to a donor or a patient by mixing their cells to see if their antibodies have a reaction. HLA typing established by serological tests where antibodies are used to detect HLA antigens (proteins) on cell surface membranes.
Split antigens	Antigens that could be mistaken for each other if tested serologically due to cross reactivity but have distinguishable differences which can be picked up on DNA level tests. Specificity of these antigens have been established (see also broad antigens)
Trait	Traits are observations about an organism that can be either seen or measured, examples include eye colour, nose shape, finger length, agreeableness, neuroticism and impulsivity. They are determined by genes and/or the environment.
Unrelated donor	A donor that is not genetically related to the recipient